

## DT7501.01 NETWORK INTERFACE FOR DISABLED TOILET ALARMS



- Connects system to standard IP networks
- Allows remote devices to monitor alarm status
- Allows remote devices to mute alarm sounder(s)
- Compatible with Folknoll graphical workstations
- Compatible with Folknoll remote monitoring
- Ideal for BMS integration, alarm loggers etc.
- Terminal rail mounting

### DISABLED TOILET ALARMS

Folknoll's vandal resistant BS8300 compliant disabled toilet alarm system provides cost-effective solutions built from standard and bespoke units. Our toilet alarms can be combined with disabled refuge EVC, fire telephone and other systems. Ideal for shops, offices, hotels and other public spaces.

### DT7501.01 NETWORK INTERFACE

The DT7501.01 Network Interface allows the disabled toilet alarm system to be extended over existing or dedicated network infrastructure.

Alarms and other events can be monitored across the network by traditional indicator panels.

Folknoll offer a range of compatible indicator panels, graphical workstations and event log PCs for monitoring alarms and system events across networks. Alternatively third party alarm monitoring, logging and control systems can be interfaced to our system to provide customised solutions.

The standard network interface is supplied in a CS rail mounting enclosure, for easy installation in racks, PSUs etc.

All connections are screw terminal or RJ45 for easy on site cabling.

## SPECIFICATIONS

Enclosure:	CS rail mounting
System / power connector:	4-way screw terminal
Network connector:	RJ 45
Power:	12 V dc (Usually supplied from battery backed system PSU)

## CONNECTIONS

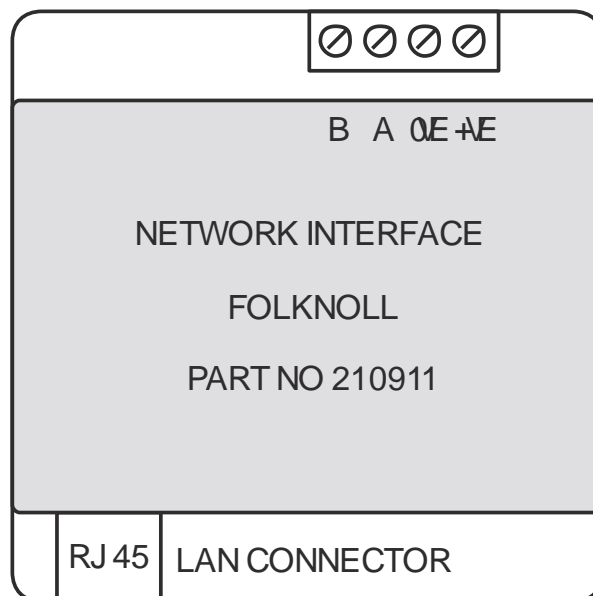

## ABOUT FOLKNOLL

We are a UK based company with over 30 years of design and manufacturing experience. All our products and systems are designed for toughness, reliability, easy installation, simple configuration, straightforward operation and low maintenance.

If you need custom engraved panels, additional features or special systems, contact us and we will be pleased to discuss your requirements.

For further information about our wide range of products and services contact us at:

**Folknoll Group Ltd.**  
Old North Rd, Royston, HERTS, SG8 5DT, UK  
+44 (0) 1763 234567 sales@folknoll.co.uk www.folknoll.co.uk