



REMOTE INDICATOR PANEL

MONITORS DISABLED TOILETS ALARMS

- Monitors up to 8-off disabled toilet alarms (256 with additional system controllers)
- Stainless steel fascia
- 16x2 LCD display
- Vandal resistant mute button
- Integral sounder
- Anti-tamper fixings
- Global alarm output for use with external equipment
- Surface or flush mount

DESCRIPTION

Remote indicator panels monitor and display the current state of the Folknoll disabled toilets alarm system.

One or more panels can be installed in central monitoring station(s) or control room(s) to attract the attention of system operators in the event of alarm activation.

Panels can be used 'stand-alone' to monitor up to 8-off disabled toilet alarms, or in conjunction with system controllers to monitor up to 256-off disabled toilet alarms.

Panels can also be daisy chained to provide disabled status indication at multiple locations.

Panels have a global alarm output for use with additional equipment e.g. external beacons/sounders or monitoring systems.

Remote indicator panels comprise a stainless steel fascia fitted with a 16x2 LCD display, an integral sounder, and mute button. The **MUTE** button is annotated in black with the word **MUTE**. Alternative annotation is available on request.

Remote indicator panels can be supplied with flush or surface mount back boxes.

NOTE: Remote indicator panels cannot be used to reset alarms. Disabled toilets alarms can only be reset at the toilet 'reset unit' to ensure operators visit the toilet area in response to an alarm.



PART NUMBERS

DT7550.80

Remote indicator panel

SPECIFICATIONS

| | |
|---------------------|---|
| Fascia: | Brush finished stainless steel |
| Mounting (surface): | Surface mount black painted mild steel back box (supplied). |
| Mounting (flush): | Or flush mount mild steel back box (supplied). |
| Dimensions: | Width: 190 mm, height: 127 mm (approx.) |
| Power: | 12VDC usually supplied by system PSU |

CONNECTIONS

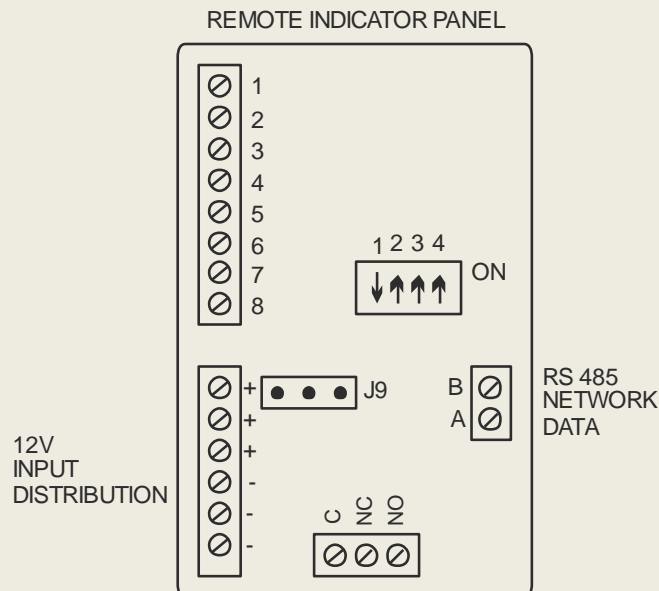

DESIGNED FOR LIFE

At Folknoll all equipment is designed by experience engineers for easy installation, simple configuration, straightforward operation, low maintenance and high reliability.

CUSTOM UNITS

Folknoll is a customer focused company. If you need special software features, custom made units or larger systems, then please contact Folknoll to discuss your requirements.

FURTHER INFORMATION

Please contact us for further information about the wide range of Folknoll products and systems.
Folknoll Group, Old North Rd, Royston, HERTS, SG8 5DT, UK

Tel: **+44 (0) 1763 234567**

Email: sales@folknoll.co.uk

www: www.folknoll.co.uk