



RESET UNIT

LOCAL OPERATOR ALARM RESET

- Suitable for stand-alone disabled toilet systems
- Compatible with remote monitoring systems
- IP/serial/digital BMS interfaces available
- Available with brush finished stainless steel fascia
- Or white painted mild steel fascia
- Vandal resistant reset button or keyed reset switch
- Anti-tamper fixings
- Surface or flush mount in 35 mm single gang back box (not supplied)

CUSTOMISED PANELS AVAILABLE ON REQUEST

DESCRIPTION

Reset units are used to reset activated disabled toilets alarms.

Units are usually mounted on a wall inside the toilet to try to ensure operators visit the alarm location in response to an alarm activation.

The unit is fitted with a vandal resistant reset button or a keyed reset switch to prevent reset by unauthorised persons.

Reset buttons or keyed switches must be held for at least 0.25 seconds to reduce the risk of an accidental alarm reset.

Reset units can be mounted in single gang 35 mm flush or surface back boxes (not supplied).

Folknoll equipment can be customised to suit your application. Alternative annotation and panel designs are available on request.

NOTE: Folknoll disabled toilets alarms cannot be reset remotely ensuring operators visit the toilet area in response to an alarm.



PART NUMBERS

DT7540.00

Reset unit, stainless steel

DT7520.27

Reset unit, white painted mild steel

SPECIFICATIONS

Fascia: (DT7540.00)

Brush finished stainless steel

Fascia: (DT7520.27)

White painted mild steel

Mounting:

35 mm single gang back box (not supplied)

Dimensions:

Width: 86 mm, height: 86 mm depth <35 mm (approx.)

Power:

12 V DC usually supplied by system PSU

CONNECTIONS

Reset Unit

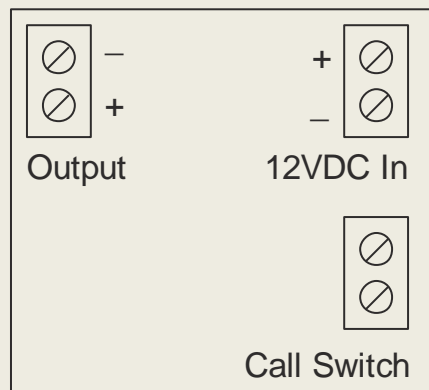

DESIGNED FOR LIFE

At Folknoll all equipment is designed by experience engineers for easy installation, simple configuration, straightforward operation, low maintenance and high reliability.

CUSTOM UNITS

Folknoll is a customer focused company. If you need special functionality, additional software features, customised panels or systems, please contact Folknoll to discuss your requirements.

FURTHER INFORMATION

Please contact us for further information about the wide range of Folknoll products and systems. Folknoll Group, Old North Rd, Royston, HERTS, SG8 5DT, UK.

Tel: **+44 (0) 1763 234567**

Email: sales@folknoll.co.uk

www: www.folknoll.co.uk