

Disabled Toilets Alarm

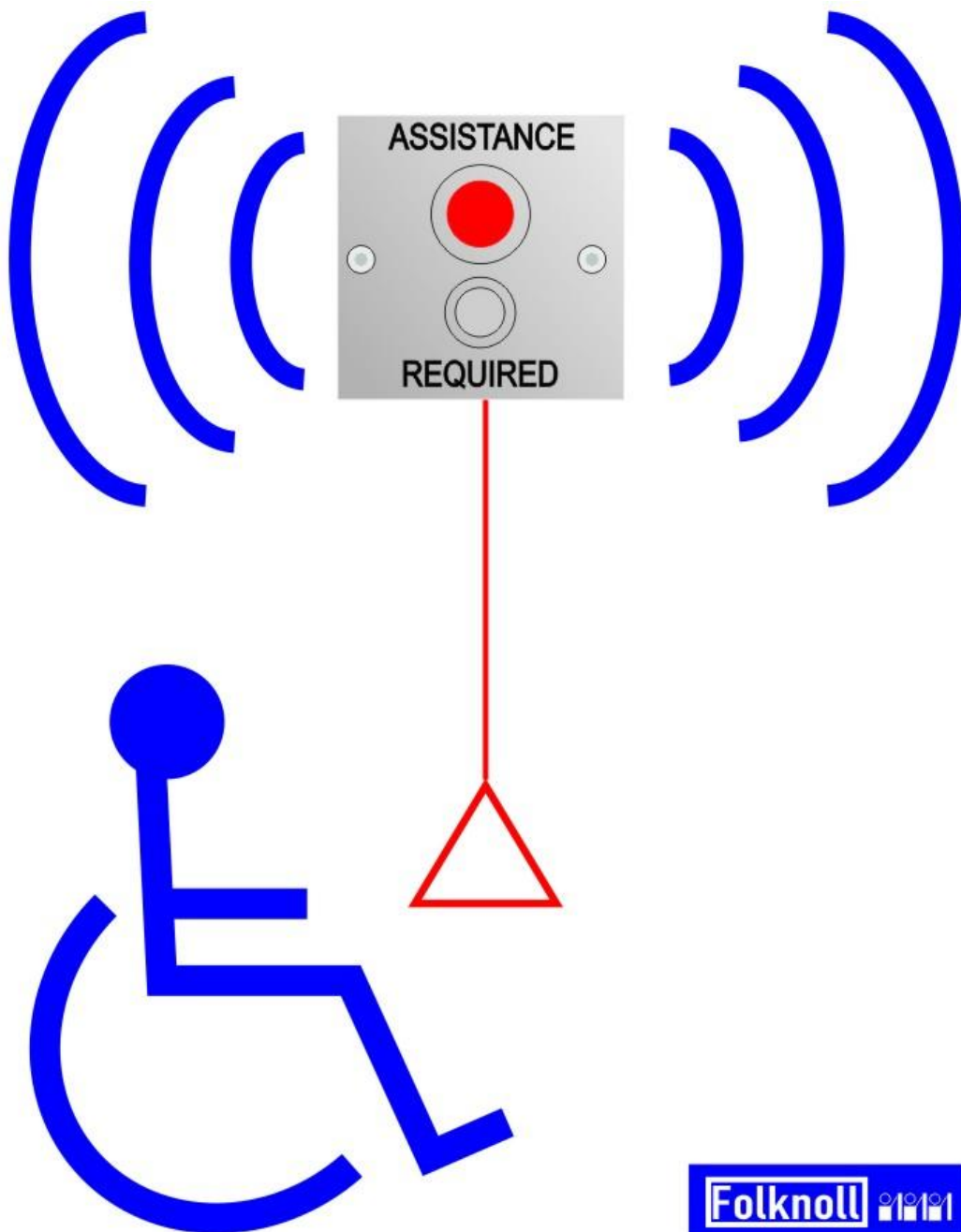

ISSUE CONTROL

Issue	Date	Changes
1.00	25.06.2010	Draft version for comment.
1.01	06.08.2010	Add remote monitoring without systems controllers.
1.02	16.01.2012	Add stainless steel pull cord. Add horizontal beacon/sounder/reset unit. Update remote panel indicator. Add remote panel indicator kit image. Update Style.

CONTENTS

1	INTRODUCTION.....	7
1.1	Features	7
1.1.1	Activators.....	7
1.1.2	Annunciators.....	7
1.1.3	Stand-Alone	7
1.1.4	Remote Monitoring	7
1.1.5	Local Reset.....	8
1.1.6	Single Battery Backed PSU	8
1.1.7	Outputs	8
1.2	Designed for Life	8
1.3	Complete Solutions	8
1.4	Custom Units	8
1.5	Contact Us	8
2	DISABLED TOILETS ALARM STAND-ALONE SYSTEM.....	9
2.1	Disabled Toilets Alarm Stand-Alone System Connections	10
3	MONITORED DISABLED TOILETS ALARM SYSTEM.....	11
3.1	Monitored Disabled Toilets System Connections	13
4	EXTENDED DISABLED TOILETS ALARM MONITORING SYSTEM.....	14
4.1	Extended Monitored Disabled Toilets Alarm System Connections	16
5	COMBINED DISABLED TOILETS ALARM AND DISABLED REFUGE EVC SYSTEM.....	17
5.1	Combined Disabled Toilets Alarm and Disabled Refuge EVC System Connections	19
6	DISABLED TOILETS ALARM STANDARD COMPONENTS	20
6.1	Standard Ceiling Pull Cord (P/N DT7520.00)	20
6.1.1	Features	20
6.1.2	Description.....	20
6.1.3	Part Numbers.....	20
6.1.4	Specifications.....	20
6.1.5	Connection.....	21
6.2	Stainless Steel Pull Cord (P/N DT7520.01)	22
6.2.1	Features	22
6.2.2	Description.....	22
6.2.3	Part Numbers.....	22
6.2.4	Specifications	22
6.2.5	Connection.....	23
6.3	Emergency Call Point (P/N DT7520.20, DT7520.25)	24
6.3.1	Features	24
6.3.2	Description.....	24
6.3.3	Part Numbers.....	24
6.3.4	Specifications	25
6.3.5	Connections	25
6.4	Beacon Unit (P/N DT7520.23)	26
6.4.1	Features	26
6.4.2	Description.....	26
6.4.3	Part Numbers.....	26
6.4.4	Specifications	26
6.5	Beacon Sounder Unit Vertical (P/N DT7520.40, DT7520.26)	27
6.5.1	Features	27
6.5.2	Description.....	27

6.5.3	Part Numbers.....	27
6.5.4	Specifications.....	27
6.5.5	Connections.....	28
6.6	Beacon/Sounder Unit Horizontal (P/N DT7520.28)	29
6.6.1	Features.....	29
6.6.2	Description.....	29
6.6.3	Part Numbers.....	29
6.6.4	Specifications.....	29
6.6.5	Connections.....	30
6.7	Reset Unit (P/N DT7540.00, DT7520.27)	31
6.7.1	Features.....	31
6.7.2	Description.....	31
6.7.3	Part Numbers.....	31
6.7.4	Specifications.....	31
6.7.5	Connections.....	32
6.8	Beacon Sounder Reset Unit Vertical (P/N DT7540.51)	33
6.8.1	Features.....	33
6.8.2	Description.....	33
6.8.3	Part Numbers.....	34
6.8.4	Specifications.....	34
6.8.5	Connections.....	34
6.9	Beacon Sounder Reset Unit Horizontal(P/N DT7520.28)	35
6.9.1	Features.....	35
6.9.2	Description.....	35
6.9.3	Part Numbers.....	35
6.9.4	Specifications.....	35
6.9.5	Connections.....	36
6.10	Beacon Reset Unit (P/N DT7540.06)	37
6.10.1	Features.....	37
6.10.2	Description.....	37
6.10.3	Part Numbers.....	38
6.10.4	Specifications.....	38
6.10.5	Connections.....	38
6.11	Beacon Call Point Unit (P/DT7520.21)	39
6.11.1	Features.....	39
6.11.2	Description.....	39
6.11.3	Part Numbers.....	39
6.11.4	Specifications.....	40
6.11.5	Connections.....	40
6.12	Remote Indicator Panel (P/N DT7550.80)	41
6.12.1	Features.....	41
6.12.2	Description.....	41
6.12.3	Part Numbers.....	42
6.12.4	Specifications.....	42
6.12.5	Connections.....	42
6.13	Remote Indicator Panel KIT (P/N DT7550.85)	43
6.13.1	Features.....	43
6.13.2	Description.....	43
6.13.3	Part Numbers.....	44
6.13.4	Specifications.....	44
6.13.5	Connections.....	45
6.14	Remote Indicator Panel Exension Kit (P/N DT7550.86)	46
6.14.1	Features.....	46
6.14.2	Description.....	46

6.14.3	Part Numbers.....	46
6.14.4	Specifications.....	46
6.14.5	Connections.....	46
6.15	LED Indicator Panel 4-Way (P/N DT7550.04)	47
6.15.1	Features.....	47
6.15.2	Description.....	47
6.15.3	Part Numbers.....	47
6.15.4	Specifications.....	47
6.15.5	Connections.....	47
6.16	System Controller (P/N DT7550.82)	48
6.16.1	Features.....	48
6.16.2	Description.....	48
6.16.3	Part Numbers.....	48
6.16.4	Specifications.....	49
6.16.5	Connections.....	49
6.17	Battery Backed System PSU (P/N DT7500.00)	50
6.17.1	Features.....	50
6.17.2	Description.....	50
6.17.3	Part Numbers.....	50
6.17.4	Specifications.....	50
6.17.5	Connections.....	51
6.18	Standard Network INTERFACE (P/N DT7501.01)	52
6.18.1	Features.....	52
6.18.2	Description.....	52
6.18.3	Part Numbers.....	52
6.18.4	Specifications.....	52
6.18.5	Connections.....	52
7	DISABLED TOILETS ALARM OPERATION.....	53
7.1	Activate an Alarm	53
7.2	On alarm	54
7.3	Reset the Alarm	55
7.4	Remote Panel Operation	56
7.5	MaNUAL System Test	58
8	INSTALLATION.....	59
9	MAINTENANCE.....	60
9.1	Routine Maintenance	60
9.1.1	Test Procedure.....	60
9.2	Fault Finding	61
9.2.1	Alarm cannot be Activated.....	61
9.2.2	Alarm Cannot be Reset.....	61
9.2.3	Remote Indicator Fail to Annunciate Alarms.....	61
9.2.4	Incorrect Alarm Message Displayed by Remote Indicator.....	61
10	USER NOTES.....	62

TABLE OF FIGURES

Fig 2:1 Typical Disabled Toilet Alarm System.....	9
Fig 2:2 Typical Stand-Alone Disabled Toilets Alarm System Connections	10
Fig 3:1 Typical Monitored Disabled Toilets Alarm System.....	12
Fig 3:2 Typical Monitored Disabled Toilets Alarm System Connections.....	13
Fig 4:1 Typical Extended Monitored Disabled Toilets Alarm System	15
Fig 4:2 Typical Extended Monitored Disabled Toilets Alarm System Connections	16
Fig 5:1 Typical Disabled Toilets System (Monitored from Disabled Refuge Panel)	18
Fig 6:1 Ceiling Pull Cord.....	20
Fig 6:2 Ceiling Pull Cord Connections.....	21
Fig 6:3 Stainless Steel Pull Cord	22
Fig 6:4 Stainless Steel Pull Cord Connections	23
Fig 6:5 Emergency Call Point.....	24
Fig 6:6 Emergency Call Point Connections.....	25
Fig 6:7 Beacon unit.....	26
Fig 6:8 Beacon Sounder Unit Vertical	27
Fig 6:9 Beacon Sounder Unit Connections.....	28
Fig 6:10 Beacon Sounder Unit Horizontal.....	29
Fig 6:11 Beacon Sounder Unit Connections.....	30
Fig 6:12 Reset Unit	31
Fig 6:13 Reset Unit Connections	32
Fig 6:14 Beacon Sounder Reset Unit Vertical	33
Fig 6:15 Beacon Sounder Reset Unit Vertical Connections	34
Fig 6:16 Beacon Sounder Reset Unit Horizontal	35
Fig 6:17 Beacon Sounder Reset Unit Connections.....	36
Fig 6:18 Beacon Reset Unit	37
Fig 6:19 Beacon Call Point Unit	39
Fig 6:20 Remote Indicator Panel.....	41
Fig 6:21 Remote Indicator Panel Connections.....	42
Fig 6:22 Remote Indicator Panel Kit.....	43
Fig 6:23 Remote Indicator Panel Kit Mounted in Compact Disabled Refuge EVC Master Station	43
Fig 6:24 Remote Indicator Panel Connections.....	45
Fig 6:25 Remote Indicator Panel Extension Kit	46
Fig 6:26 Remote Indicator Panel Extension Kit Connections.....	46
Fig 6:27 LED Indicator Panel 4-Way	47
Fig 6:28 LED Indicator Panel 4-Way Connections	47
Fig 6:29 System Controller	48
Fig 6:30 System Controller Connections.....	49
Fig 6:31 Battery Backed System Power Supply Unit.....	50
Fig 6:32 Battery Backed System Power Supply Connections.....	51
Fig 6:33 Standard Network Interface.....	52
Fig 6:34 Standard Network Interface Connections.....	52
Fig 7:1 Example Pull Cords and Emergency Call Buttons.....	53
Fig 7:2 Example Alarm Annunciators	54

Fig 7:3 Example Combined Alarm Annunciator 54
Fig 7:4 Example Multi Zone Alarm Annunciator 54
Fig 7:5 Example Reset Units 55
Fig 7:6 Remote Indicator Panel 56
Fig 7:7 Remote Indicator Panel Kit Mounted in Compact Disabled Refuge EVC Master Station 56
Fig 7:8 Remote Indicator Panel Kit..... 56
Fig 7:9 Remote Indicator Panel Kit..... 58
Fig 7:10 Remote Indicator Panel Kit Mounted in Compact Disabled Refuge EVC Master Station 58

1 INTRODUCTION

This document is the System Manual for the Folknoll Disabled Toilets Alarm System.

Folknoll manufacture a range of Disabled Toilets Alarm products designed to enable you and your client to install a wide range of vandal resistant disabled toilets alarm systems.

Folknoll Disabled Toilets Alarm systems comprise one or more stand-alone disabled toilets alarm systems with optional remote monitoring. Each stand-alone system is assembled from a range of high quality parts allowing clients to customise a system to suit their requirements. Additional options include battery backed operation, remote monitoring for up to 256 stand-alone systems, multiple indicator panels and outputs for BMS or other additional equipment.

System design, customisation and special features are available on request, please contact Folknoll with your requirements and we will be happy to assist.

1.1 FEATURES

1.1.1 Activators

Folknoll Disabled Toilets Alarms are activated by pull cords, or annotated vandal resistant buttons. More than one activator can be built into each stand-alone toilet system. Activators must be held (pulled or pressed) for a minimum of 0.25 seconds to reduce the risk of accidental alarm activation.

1.1.2 Annunciators

Folknoll offer a choice of flush or surface mounted combined beacon and sounder units to attract attention in the event of an alarm.

1.1.3 Stand-Alone

System components can be assembled to form a range of battery backed stand-alone Disabled Toilets Alarm systems complete with local alarm reset.

1.1.4 Remote Monitoring

Stand-alone toilet systems can be monitored by remote indicator panels. A single panel will monitor and report the status of up to 8-off stand-alone toilet systems. In the event of alarm activation the remote indicator panel emits an audible tone and displays a custom message identifying the source of the alarm. Eight and sixteen way Indicator panels can be built into new or existing Folknoll compact disabled refuge EVC master stations providing a cost effective and space efficient solutions.

Remote monitoring systems can be extended using system controllers. Each system controller can monitor up to 16-off stand-alone toilets. System controllers can be networked together to monitor up to 256-off stand-alone toilet systems. In an extended system the system alarm status is displayed on one or more networked remote indicator panels. In the event of alarm activation each remote indicator panel emits an audible tone and displays a custom message identifying the source of the alarm.

1.1.5 Local Reset

Folknoll Disabled Toilets Alarms can only be reset at the stand-alone toilet system, requiring operators to visit the activated disabled toilet system to cancel the alarm.

1.1.6 Single Battery Backed PSU

All systems whether stand-alone or remotely monitored can be powered from a single battery backed PSU to provide continued operation in the event of a mains failure.

This power supply can either be the standard battery backed system PSU or where remote indicator panels built into disabled refuge EVC master stations are in use it may be possible to use the existing PSU within the master station.

1.1.7 Outputs

Outputs indicating individual or global alarm activation can be provided at various points on the system for integration with BMS and other additional equipment. A network interface is also available for network alarm loggers, alarm monitors and BMS systems.

1.2 DESIGNED FOR LIFE

The Folknoll Disabled Toilets Alarm system has been designed for easy installation, simple configuration, straightforward operation, excellent testing facilities, low maintenance and high reliability.

1.3 COMPLETE SOLUTIONS

Folknoll are happy to assist in specifying equipment, configuring systems and providing connection diagrams.

1.4 CUSTOM UNITS

Folknoll is a customer focused company. If you require special software features, custom made units or larger systems, then please contact Folknoll to discuss your requirements.

1.5 CONTACT US

For further information about Folknoll Disabled Toilets Alarm Systems or any other Folknoll products please contact us on +44 (0) 1763 234567, email us at sales@folknoll.co.uk, or visit our website at www.folknoll.co.uk.

2 DISABLED TOILETS ALARM STAND-ALONE SYSTEM

The stand-alone system is an independent system for a single disabled toilet. The system comprises one or more activators, (typically ceiling pull cords and/or emergency call buttons), one or more alarm annunciators, a reset unit and a battery backed PSU. For a typical stand-alone system please refer to the diagram below:-

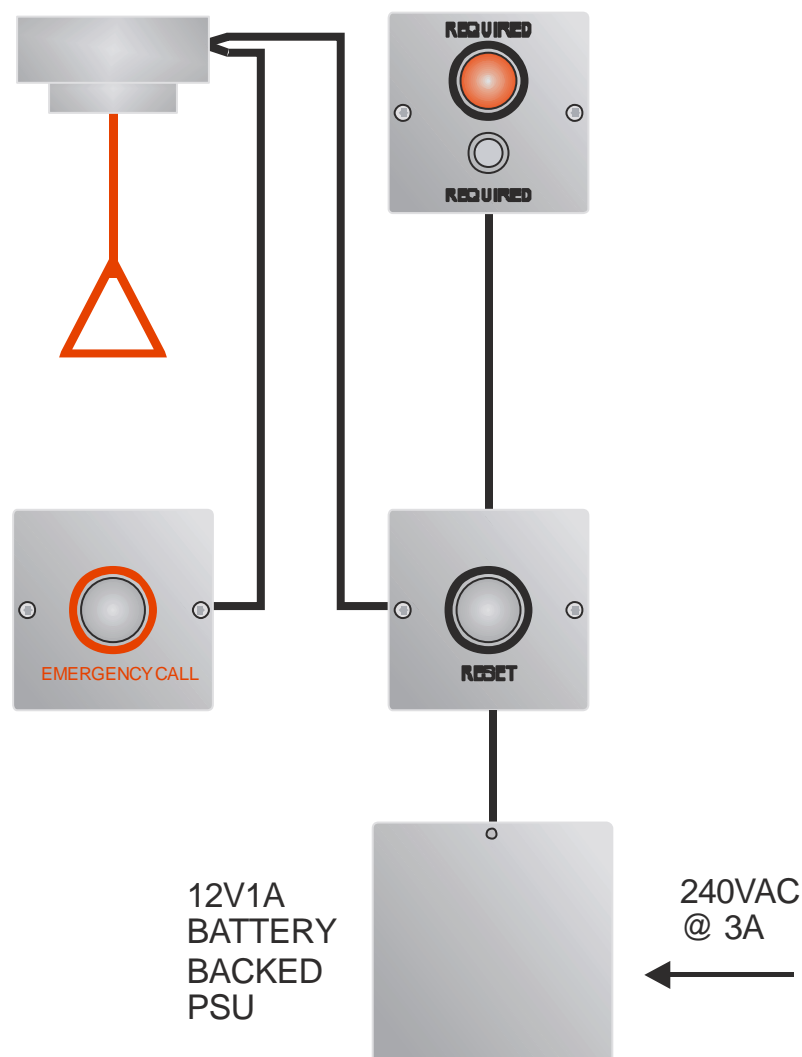

Fig 2:1 Typical Disabled Toilet Alarm System

Depending on options selected users activate alarms by pulling the pull cord or pushing the emergency call button.

Activated alarms are annunciated by illuminating the beacon and activating the sounder. After responding to the activated alarm the system is reset by pressing the reset button.

To reduce the risk of accidental alarm activation users must pull the ceiling cord or push the emergency call button for a minimum of 0.25 seconds to trigger an alarm.

The stand-alone system is powered by a battery backed PSU to ensure continued operation in the event of a main failure.

2.1 DISABLED TOILETS ALARM STAND-ALONE SYSTEM CONNECTIONS

The diagram below shows the termination connections for a typical stand-alone disabled toilets alarm system:-

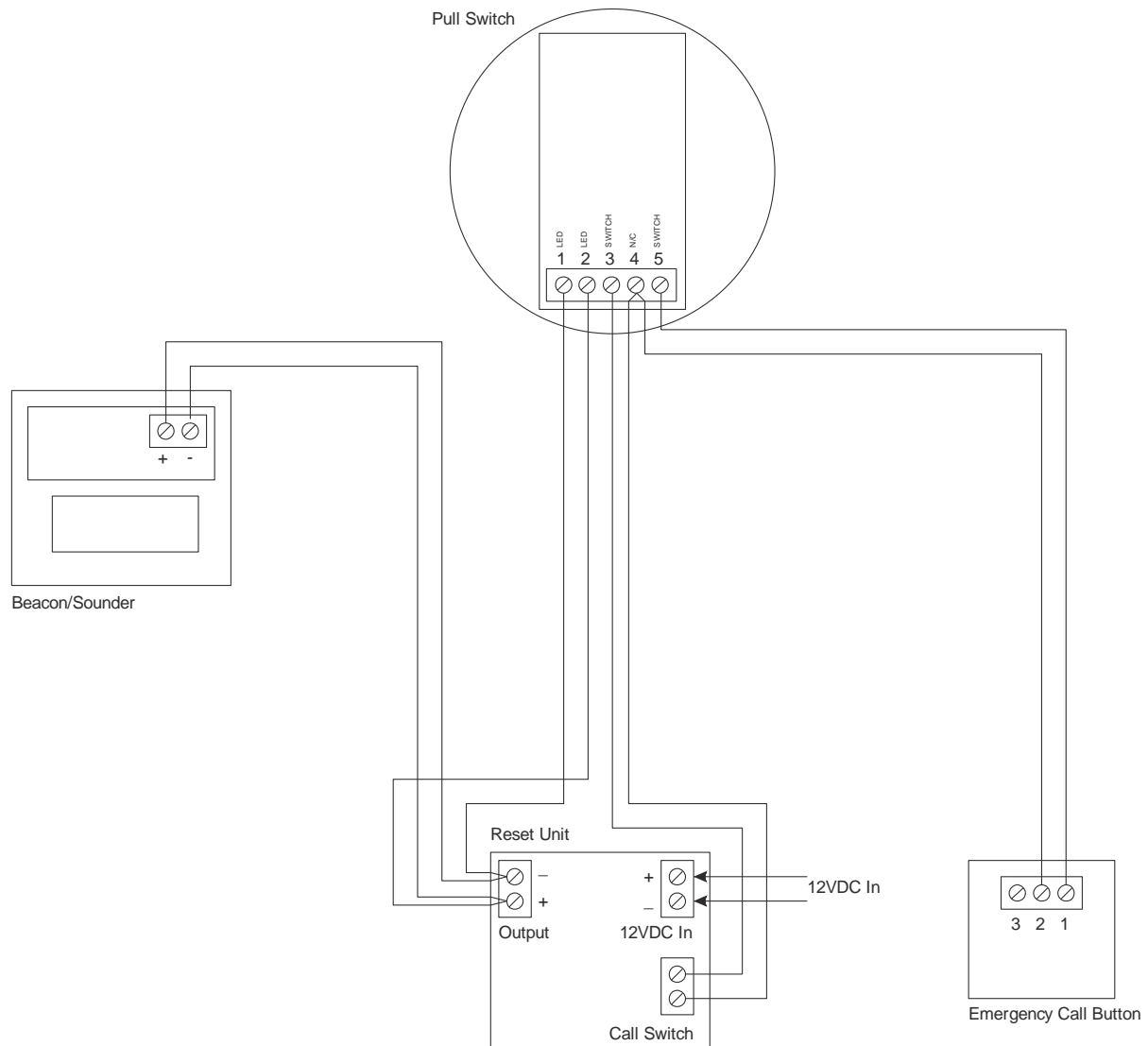

Fig 2:2 Typical Stand-Alone Disabled Toilets Alarm System Connections

Activators are wired in series to the reset unit call terminal. The alarm annunciator is wired to the reset unit output terminal. A 12V power supply is wired to the reset unit power terminals.

3 MONITORED DISABLED TOILETS ALARM SYSTEM

If remote monitoring is required up to 8-off stand-alone toilet systems can be wired to a remote indicator panel.

The system alarm status is displayed by a remote indicator panel. In the event of alarm activation on one of the stand-alone toilet systems the remote indicator panel emits an audible tone and displays a custom message identifying the source of the alarm.

The stand-alone toilet systems and the remote indicator panel are usually powered from a single battery backed power supply to ensure continued operation in the event of a mains failure.

NOTE: Folknoll Disabled Toilets Alarms can only be reset by pressing the reset button on the stand-alone toilet system, requiring operators to visit the activated disabled toilet system to cancel the alarm.

Please refer to the diagram below for a typical remotely monitored Disabled Toilets Alarm system: -

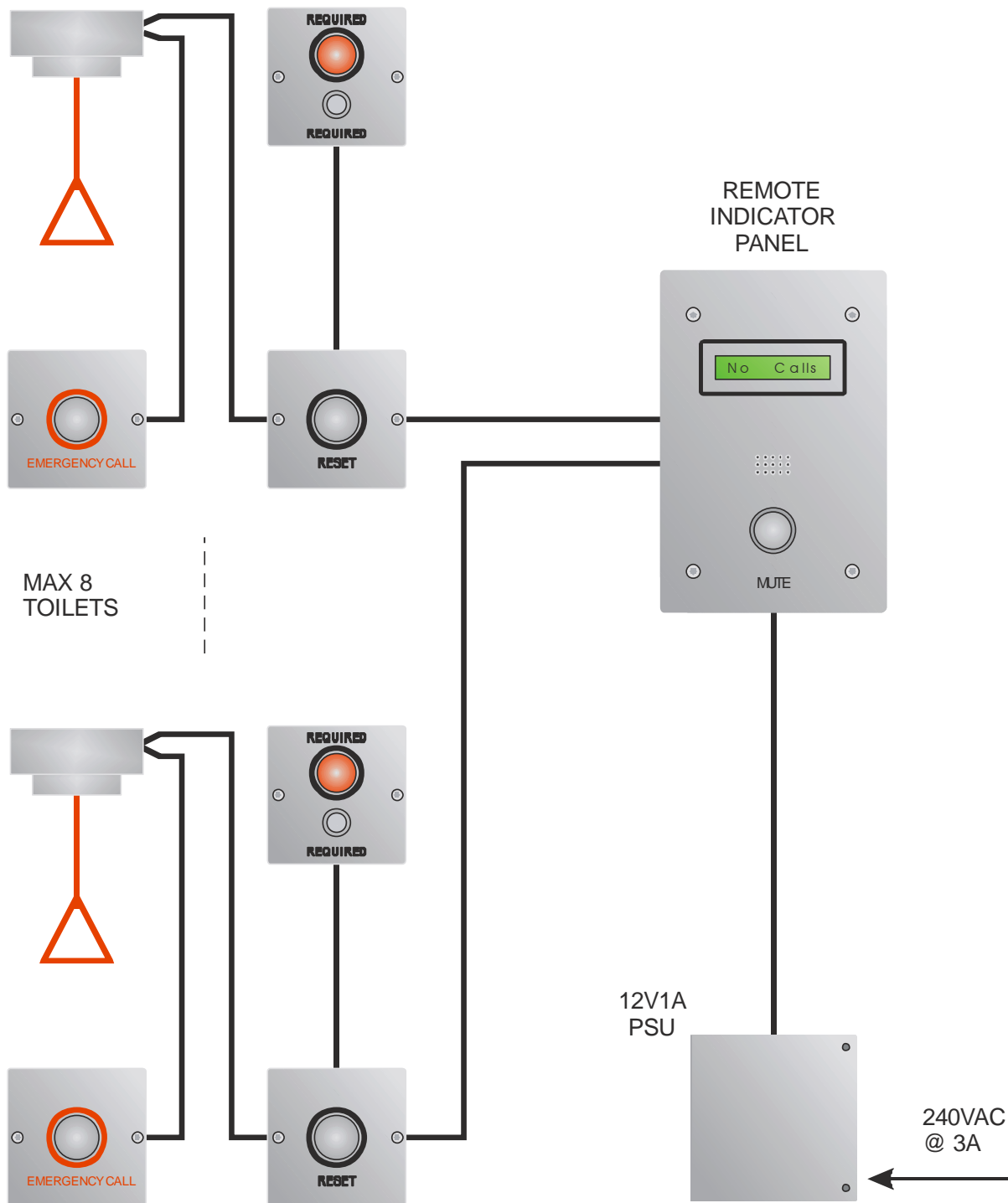

Fig 3:1 Typical Monitored Disabled Toilets Alarm System

3.1 MONITORED DISABLED TOILETS SYSTEM CONNECTIONS

Please refer to the diagram below for typical 8-off toilet remotely monitored Disabled Toilets Alarm system connections.

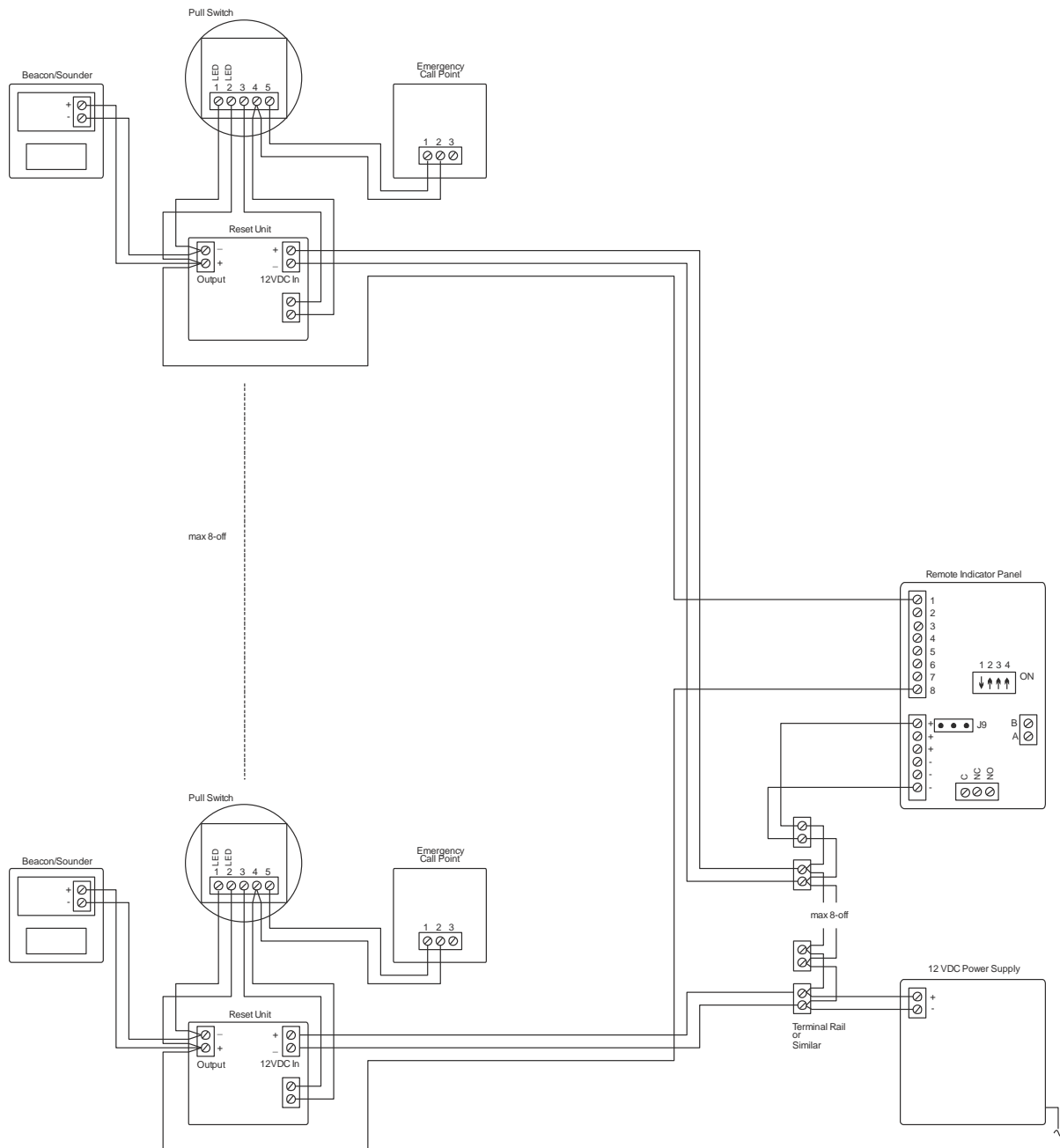

Fig 3:2 Typical Monitored Disabled Toilets Alarm System Connections

4 EXTENDED DISABLED TOILETS ALARM MONITORING SYSTEM

Monitored disabled toilets systems can be extended using system controllers.

Each system controller can monitor up to 16-off stand-alone toilet systems, and up to 16-off system controllers can be networked together to monitor up to 256-off stand-alone toilet systems.

One or more remote panel indicators can be networked to the system controllers. In the event of alarm activation on one of the stand-alone toilet systems each remote indicator panel emits an audible tone and displays a custom message identifying the source of the alarm.

All system equipment is usually powered from a single battery backed power supply to ensure continued operation in the event of a mains failure.

NOTE: Folknoll Disabled Toilets Alarms can only be reset by pressing the reset button on the stand-alone toilet system, requiring operators to visit the activated disabled toilet system to cancel the alarm.

Please refer to the diagram below for a typical extended remotely monitored Disabled Toilets Alarm system: -

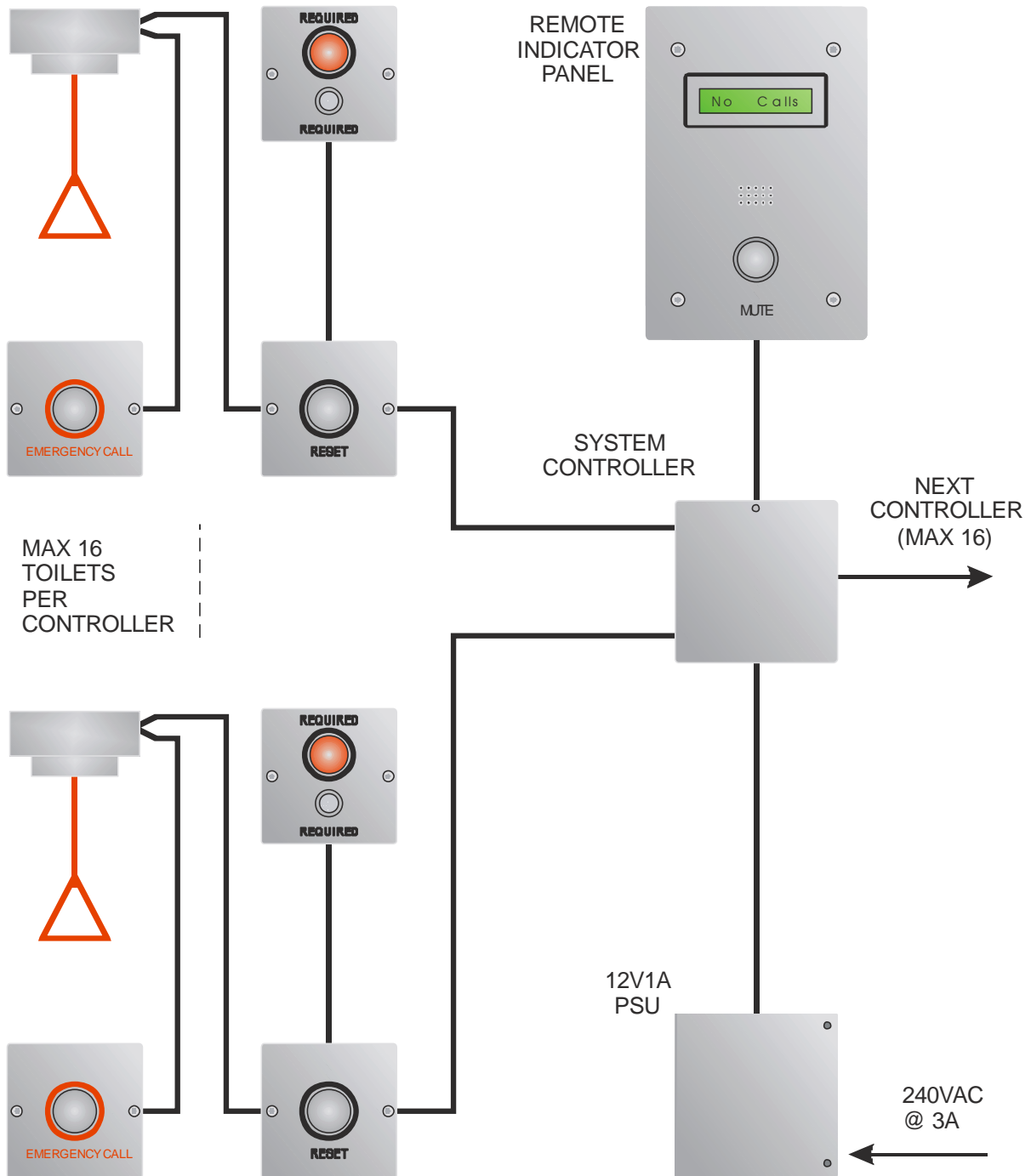

Fig 4:1 Typical Extended Monitored Disabled Toilets Alarm System

4.1 EXTENDED MONITORED DISABLED TOILETS ALARM SYSTEM CONNECTIONS

Please refer to the diagram below for typical extended remotely monitored Disabled Toilets Alarm system connections.

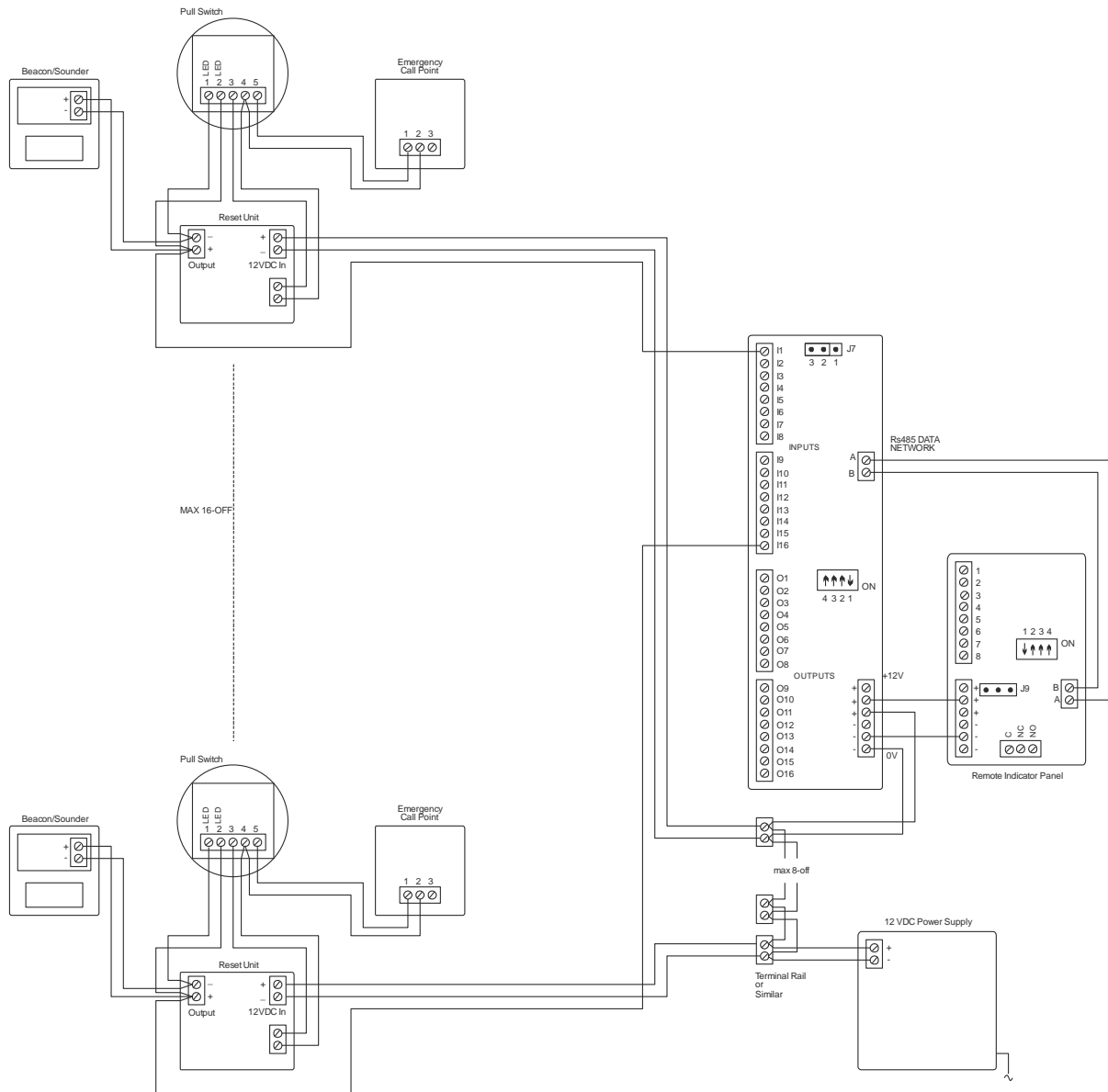

Fig 4:2 Typical Extended Monitored Disabled Toilets Alarm System Connections

System controllers and remote indicator panels are networked together over RS485. Devices are connected, by daisy chaining their A and B terminals. Care should be taken to follow the usual rules when designing an RS485 cabling system. If in doubt please contact FolknoIII.

5 COMBINED DISABLED TOILETS ALARM AND DISABLED REFUGE EVC SYSTEM

Disabled toilets systems can be monitored from a Folknoll fire panel sized compact disabled refuge EVC master station.

Folknoll offer expansion kits to add a remote indicator panel to a Folknoll compact disabled refuge EVC master station. The expansion kits allow the direct monitoring of up to 16-off toilets or networking to an extended disabled toilets system to monitor up to 256 toilets.

For an example of a directly monitored system please refer to the diagram below.

One or more remote panel indicators can be networked to the system controllers. In the event of alarm activation on one of the stand-alone toilet systems each remote indicator panel emits an audible tone and displays a custom message identifying the source of the alarm.

All system equipment is usually powered from a single battery backed power supply to ensure continued operation in the event of a mains failure.

The Folknoll compact disabled refuge EVC master station.net has a built in battery backed PSU. Depending on systems sizes and local regulations it may be possible to power the disabled toilets system from the EVC master station making a more cost effective solution.

NOTE: Folknoll Disabled Toilets Alarms can only be reset by pressing the reset button on the stand-alone toilet system, requiring operators to visit the activated disabled toilet system to cancel the alarm.

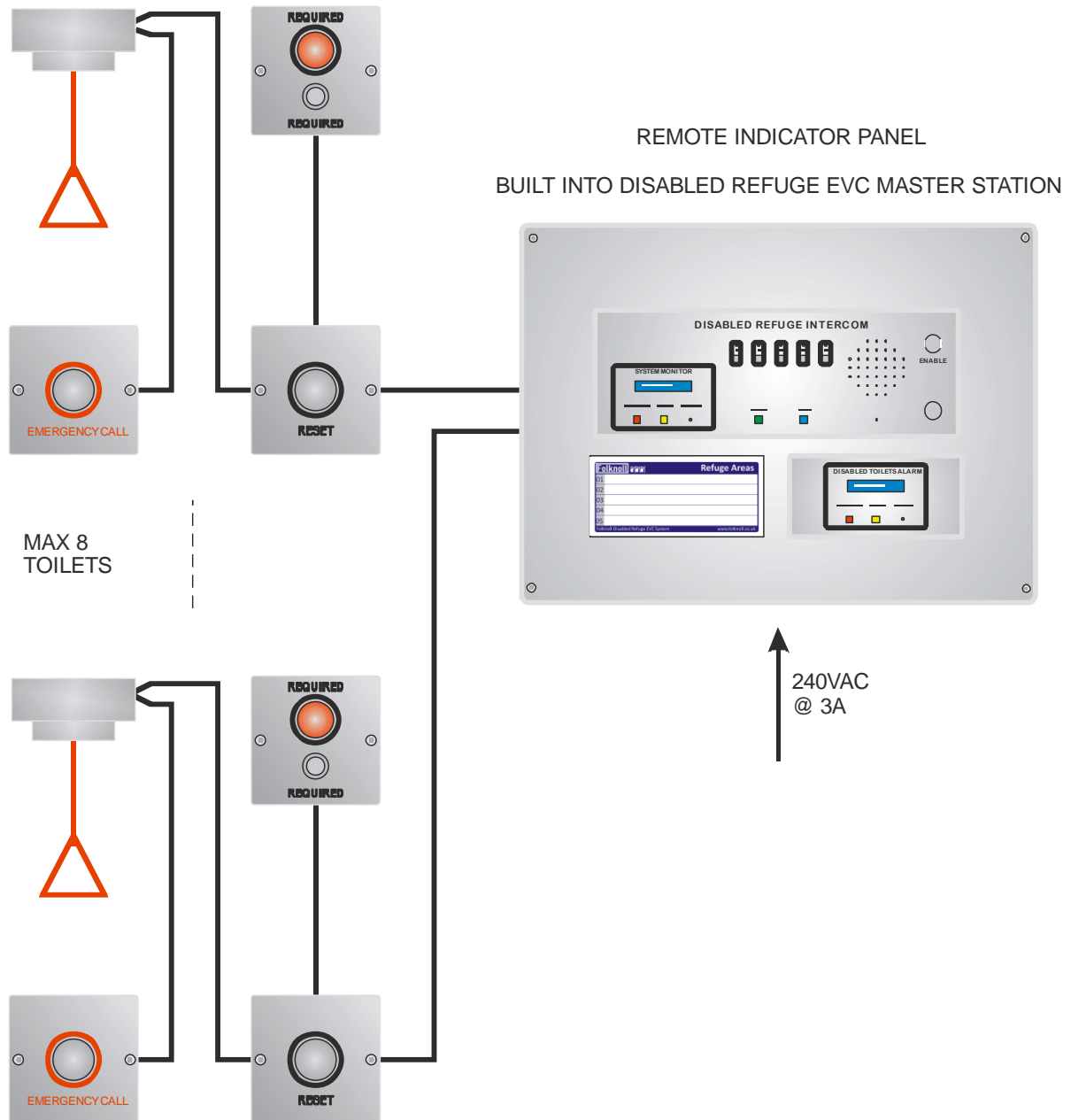

Fig 5:1 Typical Disabled Toilets System (Monitored from Disabled Refuge Panel)

NOTE: The Folknoll compact disabled refuge EVC master station.net has a built in battery backed PSU.

5.1 COMBINED DISABLED TOILETS ALARM AND DISABLED REFUGE EVC SYSTEM CONNECTIONS

The remote indicator panel built into the disabled refuge EVC master station replaces or supplements the standard remote indicator panel. Combined disabled toilets alarm and disabled refuge EVC are connected the same way as monitored and extended disabled toilets alarm, system.

Please refer to sections 3 Monitored Disabled Toilets Alarm System and 4 Extended Disabled Toilets Alarm Monitoring System for details.

6 DISABLED TOILETS ALARM STANDARD COMPONENTS

6.1 STANDARD CEILING PULL CORD (P/N DT7520.00)



Fig 6:1 Ceiling Pull Cord

6.1.1 Features

- Microswitch activator
- Activation delay
- Integral alarm activated LED for user reassurance

6.1.2 Description

Ceiling pull cords are used by users to activate disabled toilets alarms.

Usually one or more emergency call points and or pull cords are mounted inside the toilet to enable users to call for assistance.

The unit is fitted with an LED that is illuminated on alarm to provide user reassurance.

The pull cord must be held for at least 0.25 seconds to reduce the risk of accidental alarm activation.

6.1.3 Part Numbers

DT7520.00	Ceiling pull cord with integral beacon LED
-----------	--

6.1.4 Specifications

Enclosure:	Plastic
Dimensions:	Diameter: 78 mm (approx.)
Power:	Line powered

6.1.5 Connection

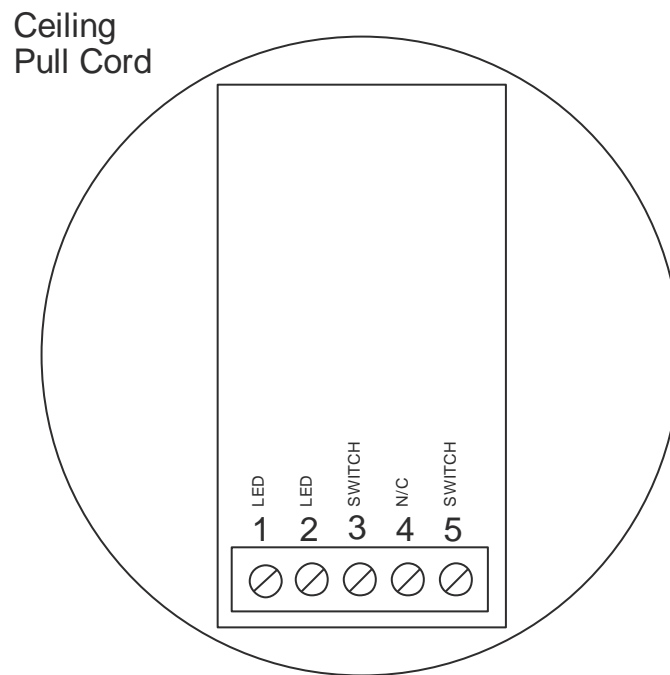

Fig 6:2 Ceiling Pull Cord Connections

Additional activators can be wired in series, (LEDs in parallel), please refer to Section 2 Disabled Toilets Alarm Stand-Alone System above.

6.2 STAINLESS STEEL PULL CORD (P/N DT7520.01)



Fig 6:3 Stainless Steel Pull Cord

6.2.1 Features

- Suitable for wall or ceiling mount
- Standard surface or flush 35mm back box (not supplied)
- Microswitch activator
- Activation delay
- Integral alarm activated LED for user reassurance

6.2.2 Description

Pull cords are used by users to activate disabled toilets alarms.

Usually one or more emergency call points and or pull cords are mounted inside the toilet to enable users to call for assistance.

The unit is fitted with an LED that is illuminated on alarm to provide user reassurance.

The pull cord must be held for at least 0.25 seconds to reduce the risk of accidental alarm activation.

6.2.3 Part Numbers

DT7520.01 Stainless Steel pull cord with integral beacon LED

6.2.4 Specifications

Fascia:	Brush finished stainless steel
Back box:	Suitable for mounting in a standard 35 mm deep single gang surface or flush back box.
Dimensions:	Width: 86 mm, Height: 86 mm (approx.)
Power:	Line powered

6.2.5 Connection

Stainless Steel Pull Cord

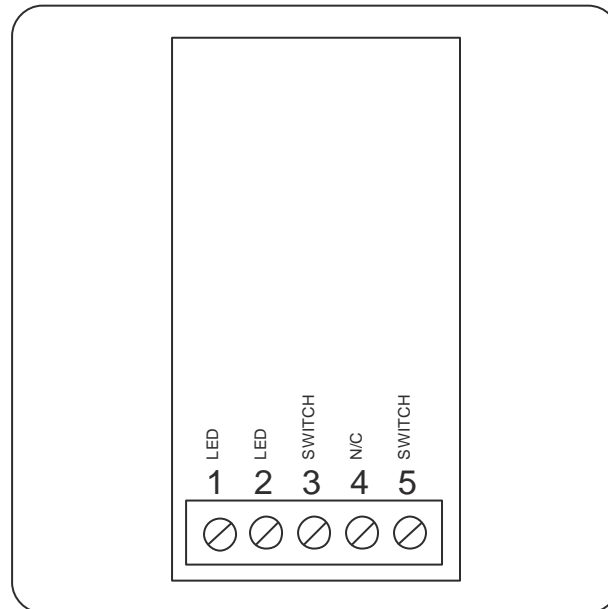

Fig 6:4 Stainless Steel Pull Cord Connections

Additional activators can be wired in series, (LEDs in parallel), please refer to Section 2 Disabled Toilets Alarm Stand-Alone System above.

6.3 EMERGENCY CALL POINT (P/N DT7520.20, DT7520.25)



Fig 6:5 Emergency Call Point

6.3.1 Features

- Vandal resistant call button
- Activation delay
- Internal anti-tamper switch
- Can be flush or surface mounted in 35mm single gang back box (not supplied)
- Available in brush finished stainless steel or white painted mild steel

6.3.2 Description

Emergency call points are used by users to activate disabled toilets alarms.

Usually one or more emergency call points and or ceiling pull cords are mounted inside the toilet to enable users to call for assistance.

These units are fitted with vandal resistant call buttons and an internal anti-tamper switches.

Call buttons must be pressed for a minimum of 0.25 seconds to reduce the risk of accidental alarm activation.

The internal anti-tamper switches trigger alarms when the front panels are removed.

The standard unit is annotated in red with the words **EMERGENCY CALL**; alternative annotation is available on request.

These units can be installed in standard 35mm single gang flush or surface mount back box (not supplied).

6.3.3 Part Numbers

DT7520.20	Emergency call point, stainless steel
DT7620.25	Emergency call point, white painted mild steel

6.3.4 Specifications

Fascia: (DT7520.20)	Brush finished stainless steel
Fascia: (DT7520.25)	White painted mild steel
Mounting:	35mm single gang back box required (not supplied)
Dimensions:	Width: 86 mm, height: 86mm Depth <35 mm (approx.)
Power:	Not required

6.3.5 Connections

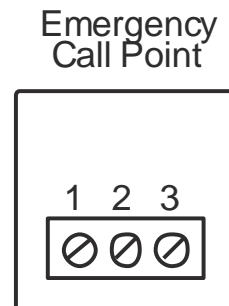

Fig 6:6 Emergency Call Point Connections

Additional activator switches can be wired in series, if required, please refer to Section 2 Disabled Toilets Alarm Stand-Alone System above.

NOTE: During installation care must be taken to locate the tamper switch spring square against the back box to false alarm activation.

6.4 BEACON UNIT (P/N DT7520.23)



Fig 6:7 Beacon unit

6.4.1 Features

- 20mm LED beacon
- Can be flush or surface mounted in 35mm single gang back box (not supplied)

6.4.2 Description

Beacon units are local alarm annunciators.

One or more of these units is usually mounted on a wall at a strategic location outside the toilet to attract attention in the event of an alarm.

The unit is fitted with a red LED beacon which illuminates to indicate that its associated alarm has been activated.

The standard unit is annotated in red with the words **ASSISTANCE REQUIRED**; alternative annotation is available on request.

The unit can be mounted in a single gang 35mm flush or surface mount back box (not supplied).

6.4.3 Part Numbers

DT7520.23 Beacon unit, stainless steel

6.4.4 Specifications

Fascia:	Brush finished stainless steel
Mounting:	35mm single gang back box required (not supplied)
Dimensions:	Width: 86 mm, height: 86 mm Depth <35 mm (approx.)
Power:	Line powered

6.5 BEACON SOUNDER UNIT VERTICAL (P/N DT7520.40, DT7520.26)



Fig 6:8 Beacon Sounder Unit Vertical

6.5.1 Features

- 20mm LED beacon
- Integral sounder
- Can be flush or surface mounted in 35mm single gang back box (not supplied)
- Available in brush finished stainless steel or white painted mild steel

6.5.2 Description

Beacon sounder units combine the functions of beacon and sounder into a single unit.

These units are usually mounted on a wall outside of the toilet to attract attention in the event of an alarm.

These units are fitted with 20mm red LED beacons and integral sounders.

Alarm activation is indicated by illuminated beacons and activated sounders.

The standard unit is annotated in black with the words **ASSISTANCE REQUIRED**; alternative annotation is available on request.

These units can be mounted in single gang 35mm flush or surface mount back boxes (not supplied).

6.5.3 Part Numbers

DT7520.40	Beacon sounder unit, vertical, stainless steel
DT7520.26	Beacon sounder unit, vertical, white painted mild steel

6.5.4 Specifications

Fascia: (DT7520.40)	Brush finished stainless steel
Fascia: (DT7520.26)	White painted mild steel
Mounting:	Standard single gang back box required (not supplied)
Dimensions:	Width: 86 mm, height: 86 mm Depth <35 mm (approx.)
Power:	Line powered

6.5.5 Connections

Beacon/Sounder Unit

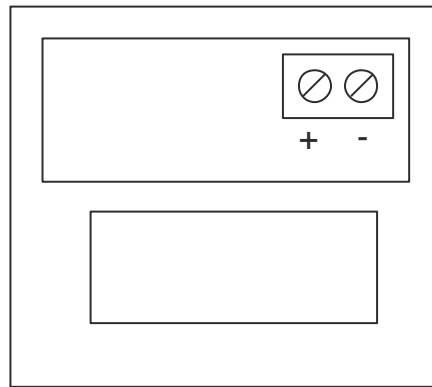

Fig 6:9 Beacon Sounder Unit Connections

6.6 BEACON/SOUNDER UNIT HORIZONTAL (P/N DT7520.28)



Fig 6:10 Beacon Sounder Unit Horizontal

6.6.1 Features

- 20mm LED beacon
- Integral sounder
- Can be flush or surface mounted in 35mm double gang back box (not supplied)
- Available in brush finished stainless steel or white painted mild steel

6.6.2 Description

Beacon sounder units are used as local alarm annunciators.

One or more of these units is usually mounted on a wall at a strategic location outside of the toilet to attract attention in the event of an alarm.

The unit is fitted with a red LED beacon and an integral sounder.

An active alarm is indicated by an illuminated beacon and active sounder.

The standard unit is annotated in black with the words **ASSISTANCE REQUIRED**; alternative annotation is available on request.

The unit can be mounted in a double gang 35mm flush or surface mount back box (not supplied).

6.6.3 Part Numbers

DT7520.28 Beacon sounder, horizontal, stainless steel

6.6.4 Specifications

Fascia:	Brush finished stainless steel
Mounting:	35mm double gang back box (not supplied)
Dimensions:	Width: 146 mm, height: 86 mm Depth <35 mm (approx.)
Power:	Line powered

6.6.5 Connections

Beacon/Sounder Unit

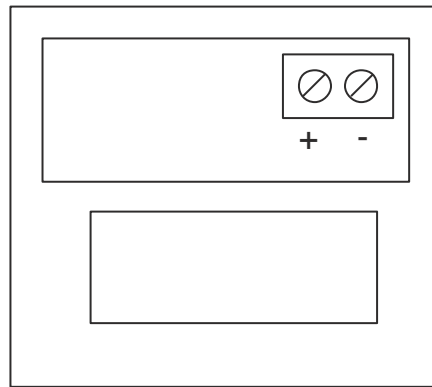

Fig 6:11 Beacon Sounder Unit Connections

6.7 RESET UNIT (P/N DT7540.00, DT7520.27)



Fig 6:12 Reset Unit

6.7.1 Features

- Vandal resistant reset button
- Can be flush or surface mounted in 35mm single gang back box (not supplied)
- Available in brush finished stainless steel or white painted mild steel

6.7.2 Description

Reset units are used to reset activated disabled toilets alarms.

These units are usually mounted on the wall inside toilet to try to ensure that an operator visits the location in response to an alarm.

Reset units are fitted with vandal resistant reset buttons. The reset button must be held for a minimum of 0.25 seconds to reduce the risk of accidental alarm reset.

This standard unit is annotated in black with the word **RESET**, alternative annotation is available on request.

These units can be mounted in single gang 35mm flush or surface mount back boxes (not supplied).

6.7.3 Part Numbers

DT7540.00	Reset unit, stainless steel
DT7520.27	Reset unit, white painted mild steel

6.7.4 Specifications

Fascia: (DT7540.00)	Brush finished stainless steel
Fascia: (DT7520.27)	White painted mild steel
Mounting:	35mm single gang back box (not supplied)
Dimensions:	Width: 86 mm, height: 86 mm Depth <35 mm (approx.)
Power:	12 VDC usually supplied by system PSU

6.7.5 Connections

Reset Unit

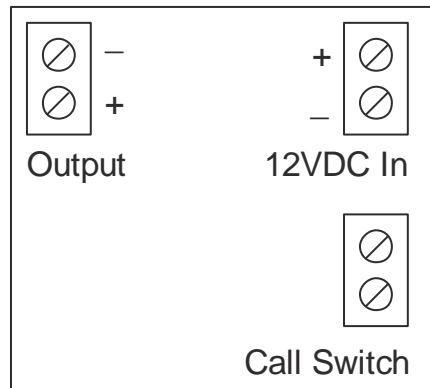

Fig 6:13 Reset Unit Connections

6.8 BEACON SOUNDER RESET UNIT VERTICAL (P/N DT7540.51)



Fig 6:14 Beacon Sounder Reset Unit Vertical

6.8.1 Features

- 20m LED beacon
- Integral sounder
- Vandal resistant button or keyed reset switch
- Can be flush or surface mounted in 35mm double gang back box (not supplied)

6.8.2 Description

Beacon sounder reset units combine the functions of alarm beacon, alarm sounder and reset unit into a single unit.

These units are usually mounted on the wall outside the toilet to attract attention in the event of an alarm and to allow operator access to reset alarms.

These units are usually supplied with vandal resistant reset buttons but can be supplied with keyed reset switches to prevent reset by unauthorised persons.

Reset button/switch must be held for at least 0.25 seconds to reduce the risk of an accidental alarm reset.

This standard unit is annotated in black with the words **ASSISTANCE REQUIRED RESET**; alternative annotation is available on request.

These units can be mounted in double gang 35mm flush or surface mount back boxes (not supplied).

NOTE: Please refer to local regulations before installing a disabled toilets alarm system.

6.8.3 Part Numbers

DT7540.51 Beacon sounder reset unit, vertical stainless steel

6.8.4 Specifications

Fascia: Brush finished stainless steel
Mounting: 35mm double gang back box (not supplied).
Dimensions: Width: 86 mm, height: 146 mm Depth <35 mm (approx.)
Power: 12 VDC usually supplied by system PSU

6.8.5 Connections

Vertical
Beacon/Sounder/Reset Unit

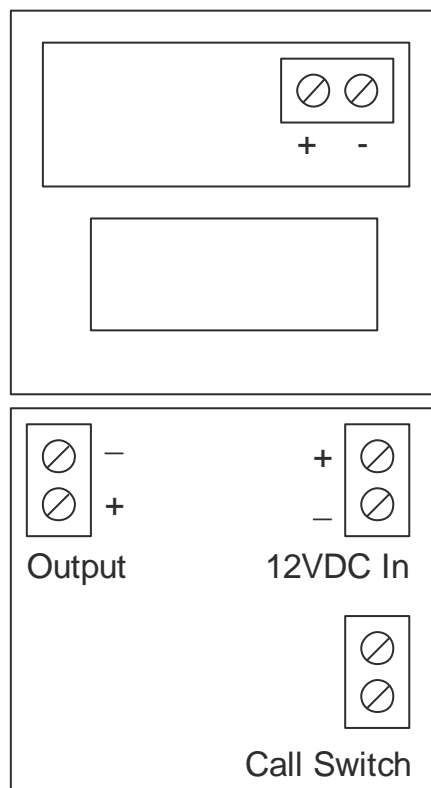

Fig 6:15 Beacon Sounder Reset Unit Vertical Connections

6.9 BEACON SOUNDER RESET UNIT HORIZONTAL(P/N DT7520.28)



Fig 6:16 Beacon Sounder Reset Unit Horizontal

6.9.1 Features

- 20m LED beacon
- Integral sounder
- Vandal resistant reset button
- Can be flush or surface mounted in 35mm double gang back box (not supplied)

6.9.2 Description

Beacon sounder reset units combine the functions of alarm beacon, alarm sounder and reset unit into a single unit.

These units are usually mounted on the wall outside the toilet to attract attention in the event of an alarm and to allow operator access to reset alarms.

These units are usually supplied with vandal resistant reset buttons but can be supplied with keyed reset switches to prevent reset by unauthorised persons.

Reset button/switch must be held for at least 0.25 seconds to reduce the risk of an accidental alarm reset.

This standard unit is annotated in black with the words **ASSISTANCE REQUIRED AUTHORISED PERSONNEL RESET**; alternative annotation is available on request.

These units can be mounted in double gang 35mm flush or surface mount back boxes (not supplied).

NOTE: Please refer to local regulations before installing a disabled toilets alarm system.

6.9.3 Part Numbers

DT7520.28 Beacon sounder reset unit, horizontal stainless steel

6.9.4 Specifications

Fascia:	Brush finished stainless steel
Mounting:	35mm double gang back box (not supplied).
Dimensions:	Width: 146 mm, height: 86 mm Depth <35 mm (approx.)
Power:	12 VDC usually supplied by system PSU

6.9.5 Connections

Horizontal
Beacon/Sounder/Reset Unit

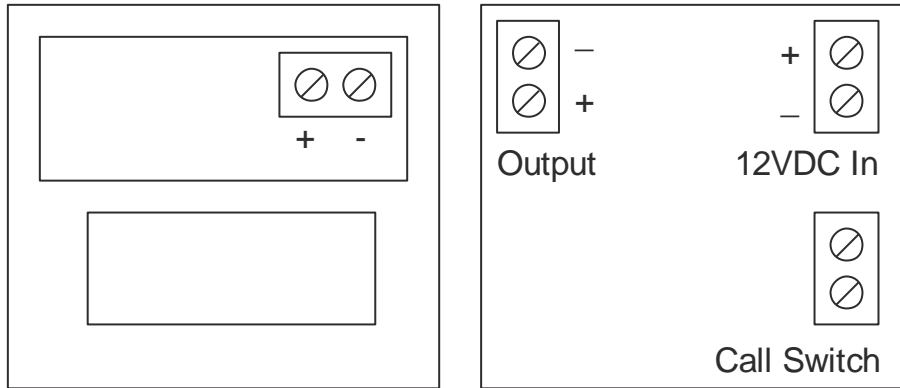

Fig 6:17 Beacon Sounder Reset Unit Connections

6.10 BEACON RESET UNIT (P/N DT7540.06)



Fig 6:18 Beacon Reset Unit

6.10.1 Features

- 20m LED beacon
- Vandal resistant reset button or keyed reset switch
- Can be flush or surface mounted in 35mm double gang back box (not supplied)

6.10.2 Description

Beacon reset units combine the function of alarm beacon, and reset unit into a single unit.

These units are usually mounted on the wall outside toilet to attract attention in the event of an alarm and to allow operator access to reset alarms.

These units are usually supplied with a vandal resistant reset button but can be supplied with a keyed reset switch to prevent reset by unauthorised persons.

Reset buttons/switches must be held for at least 0.25 seconds to reduce the risk of an accidental alarm reset.

Standard unit are annotated in black with the words **RESET**; alternative annotation is available on request.

These units can be mounted in double gang 35mm flush or surface mount back boxes (not supplied).

NOTE: Please refer to local regulations before installing a disabled toilets alarm system.

6.10.3 Part Numbers

DT7540.06 Beacon reset unit, stainless steel

6.10.4 Specifications

Fascia: Brush finished stainless steel
Mounting: 35mm double gang back box (not supplied).
Dimensions: Width: 86 mm, height: 146 mm Depth <35 mm (approx.)
Power: 12 VDC usually supplied by system PSU

6.10.5 Connections

6.11 BEACON CALL POINT UNIT (P/DT7520.21)

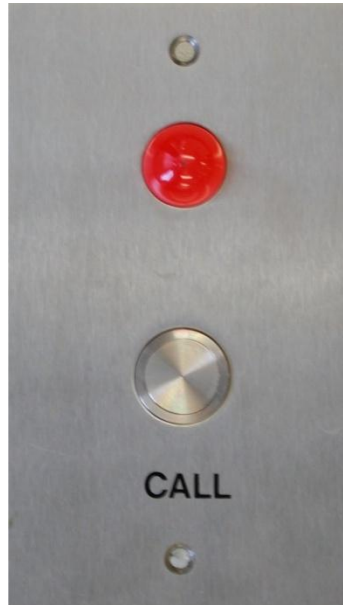

Fig 6:19 Beacon Call Point Unit

6.11.1 Features

- 20m LED beacon
- Vandal resistant call button
- Can be flush or surface mounted in 35mm double gang back box (not supplied)

6.11.2 Description

Beacon call point units combine the functions of alarm beacon, and emergency call point into a single unit.

These units are usually mounted on the wall inside a toilet to enable a user to call for assistance.

The beacon is illuminated when the alarm is activated to provide reassurance that the alarm has been activated.

The call button must be held for at least 0.25 seconds to reduce the risk of an accidental alarm reset.

The standard unit is annotated in black with the words **CALL**; alternative annotation is available on request.

These units can be mounted in double gang 35mm flush or surface mount back boxes (not supplied).

NOTE: Please refer to local regulations before installing a disabled toilets alarm system.

6.11.3 Part Numbers

DT7520.21 Beacon call point unit, stainless steel

6.11.4 Specifications

Fascia:	Brush finished stainless steel
Mounting:	35mm double gang back box (not supplied).
Dimensions:	Width: 86 mm, height: 86 mm Depth <35 mm (approx.)
Power:	Line powered

6.11.5 Connections

6.12 REMOTE INDICATOR PANEL (P/N DT7550.80)



Fig 6:20 Remote Indicator Panel

6.12.1 Features

- LCD display
- Integral sounder
- Mute button
- Can be used to monitor up to 8-off toilets
- Can be used in conjunction with system controllers to monitor up to 256 toilets
- Surface or flush mount back box supplied

6.12.2 Description

Remote indicator panels display the current disabled toilets system alarm state.

One or more of these units are usually installed in central monitoring station(s) or control room(s) to attract the attention of system operators in the event of an alarm.

These units can be used to directly monitor up to 16-off toilets. They can also be used in conjunction with system controllers to monitor up to 256 toilets, please refer to sections 3 Monitored Disabled Toilets Alarm System and 4 Extended Disabled Toilets Alarm Monitoring System. Remote panel indicators can be daisy chained together to provide monitoring at multiple locations.

Remote indicator panels cannot be used to reset alarms. Disabled toilets alarms are reset at the toilet to ensure operators visit the toilets in response to an alarm.

These units are fitted with a 16x2 LCD display, an integral sounder, mute button and a global alarm output for use with additional equipment.

The **MUTE** button is annotated in black with the word **MUTE**, alternative button annotation and panel annotation is available on request.

This unit can be supplied with a flush or surface mount back box.

If no alarms are active the LCD shows **SYSTEM OK**.

On alarm the integral sounder is activated and a message identifying the alarm source is shown on the LCD display. The alarm source message is a customisable alphanumeric string of up to 16 characters, please contact Folknoll for details.

If more than one alarm is active simultaneously the remote panel indicator LCD display will scroll through a list of active alarms.

If required the sounder can be silenced by pressing the **MUTE** button. The **MUTE** button will automatically mute the sounders on all of the remote indicator panels in the system

6.12.3 Part Numbers

DT7550.80 Remote indicator panel

6.12.4 Specifications

Fascia:	Brush finished stainless steel
Mounting (surface):	Surface mount black painted mild steel back box (supplied).
Mounting (flush):	Or flush mount mild steel back box (supplied).
Dimensions:	Width: 190 mm, height: 127 mm (approx.)
Power:	12VDC usually supplied by system PSU

6.12.5 Connections

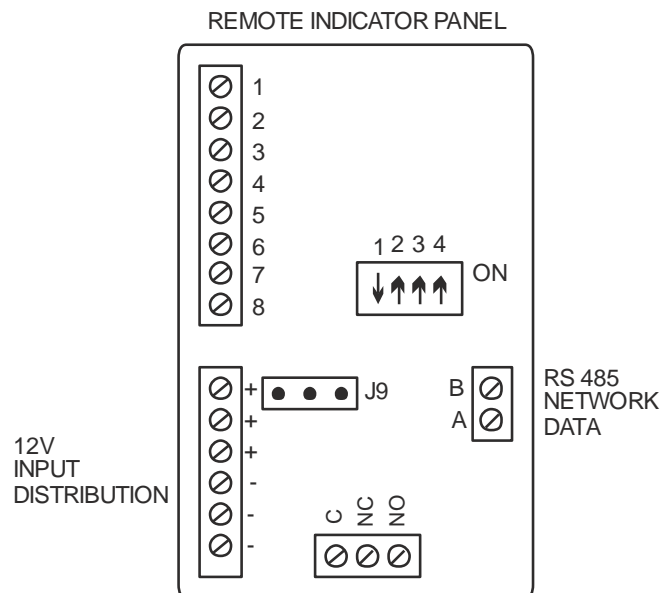

Fig 6:21 Remote Indicator Panel Connections

System controllers and remote indicator panels are networked using the AB terminals please refer to section 4 Extended Disabled Toilets Alarm Monitoring System above.

6.13 REMOTE INDICATOR PANEL KIT (P/N DT7550.85)



Fig 6:22 Remote Indicator Panel Kit

The remote indicator panel kit is usually mounted inside a Disabled Refuge EVC master station for example:-



Fig 6:23 Remote Indicator Panel Kit Mounted in Compact Disabled Refuge EVC Master Station

6.13.1 Features

- LCD display
- Integral sounder
- Mute button
- Test button
- LED fault indicator
- Monitors up to 8-off toilet alarms
- Can be combined with an extension kit to monitor up to 16-off toilet alarms
- Mounts inside Folknoll Compact Disabled Refuge System master station

6.13.2 Description

Remote indicator panel kits are mounted inside compact disabled refuge EVC master stations and display the current disabled toilets system alarm state.

Compact disabled refuge EVC master stations are usually installed in central monitoring station(s) or control room (s) to attract the attention of system operators in the event of an alarm.

The unit is fitted with a 16x2 LCD display, an integral sounder, mute button and a global alarm output for use with additional equipment.

Remote panel indicators can be daisy chained together to provide monitoring at multiple locations.

If no alarms are active the LCD shows **SYSTEM OK**.

On alarm the integral sounder is activated and a message identifying the alarm source is shown on the LCD display. The alarm source message is a customisable alphanumeric string of up to 16 characters, please contact Folknoll for details.

If more than one alarm is active simultaneously the remote indicator panel LCD display will scroll through a list of active alarms.

If required the sounder can be silenced by pressing the **MUTE** button. The **MUTE** button will automatically mute the sounders on all of the remote indicator panels in the system

The remote indicator panel cannot be used to reset alarms. To try to ensure operators visit toilets in response to an alarm Folknoll Disabled Toilets Alarms cannot be reset remotely.

This unit is usually mounted inside and powered from a Folknoll Compact Disabled Refuge Master.

6.13.3 Part Numbers

DT7750.85	Remote Panel Indicator Kit for Compact Disabled Refuge EVC Master Station
-----------	---

6.13.4 Specifications

Mounting:	This unit is usually mounted inside a compact disabled refuge EVC master station.
Dimensions:	Width: TBA mm, height: TBA mm Depth TBA mm (approx.)
Power:	12VDC, this unit is usually powered from the disabled refuge EVC master station battery backup power supply.

6.13.5 Connections

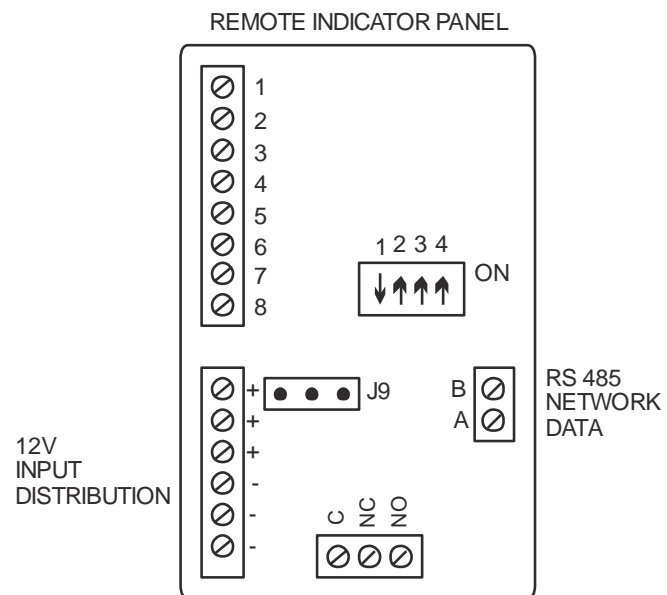

Fig 6:24 Remote Indicator Panel Connections

System controllers and remote indicator panels are networked using the AB terminals please refer to section 4 Extended Disabled Toilets Alarm Monitoring System above.

6.14 REMOTE INDICATOR PANEL EXTENSION KIT (P/N DT7550.86)

IMAGE NOT CURRENTLY AVAILABLE

Fig 6:25 Remote Indicator Panel Extension Kit

6.14.1 Features

- Extends remote indicator panel kit to up to 16-off toilets
- Mounts inside Folknoll compact disabled refuge system EVC master station

6.14.2 Description

This unit combines with the remote panel indicator compact disabled refuge system EVC master station to monitor up to 16-off toilets.

Please refer to section 6.13 Remote Indicator Panel KIT (P/N DT7550.85).

This unit is mounted inside and powered from a Folknoll compact disabled refuge system EVC master station.

6.14.3 Part Numbers

DT7550.86	Remote indicator panel extension for a Folknoll compact disabled refuge system EVC master station.
-----------	--

6.14.4 Specifications

Mounting:	This unit is usually mounted inside a disabled refuge EVC master station.
Dimensions:	Width: TBA mm, height: TBA mm Depth TBA mm (approx.)
Power:	12VDC, this unit is usually powered from the disabled refuge EVC master station battery backup power supply

6.14.5 Connections

IMAGE NOT AVAILABLE

Fig 6:26 Remote Indicator Panel Extension Kit Connections

6.15 LED INDICATOR PANEL 4-WAY (P/N DT7550.04)



Fig 6:27 LED Indicator Panel 4-Way

6.15.1 Features

- 4-off 20mm LED beacon
- Integral sounder
- Brush finished stainless steel

6.15.2 Description

LED Indicator panels annunciates the alarm and indicates which zone is activated, can be used for remote alarm monitoring in place of remote indicator panels.

These units are fitted with 20mm red LED beacons and an integral sounder.

Alarm activation is indicated by illuminated beacons and activated sounder.

The standard unit is annotated in black with the words **ZONES 1 2 3 4**; alternative annotation is available on request.

6.15.3 Part Numbers

DT7550.04 LED Indicator panel, stainless steel, 4-way

6.15.4 Specifications

Fascia:	Brush finished stainless steel
Mounting:	TBA
Dimensions:	Width: TBA mm, height: TBA mm Depth TBA mm (approx.)
Power:	Line powered

6.15.5 Connections

IMAGE NOT AVAILABLE

Fig 6:28 LED Indicator Panel 4-Way Connections

6.16 SYSTEM CONTROLLER (P/N DT7550.82)



Fig 6:29 System Controller

6.16.1 Features

- Fully enclosed surface mount enclosure
- Monitors up to 16-off toilets
- Can be networked to up to 15-off additional units to monitor a total of 256 toilets
- Can be networked to one or more remote panel indicators to alert operators
- Outputs for BMS or other systems

6.16.2 Description

These units monitor up to 16-off stand-alone Disabled Toilets Alarm systems, and reports alarm events to remote indicator panels.

System controllers are usually installed in central or distributed equipment rooms.

The unit houses individual alarm state outputs for use with additional equipment.

Up to 16-off controllers can be networked together to provide monitoring for up to 256-off toilet alarms.

System controllers are networked with the remote indicator panels over RS485. Care should be taken to observe the normal design rules, please refer to section 4 Extended Disabled Toilets Alarm Monitoring System above.

System Controllers are supplied in surface mount enclosures.

6.16.3 Part Numbers

DT7550.82

Boxed 16-way system controller

6.16.4 Specifications

Enclosure: White painted mild steel
 Mounting: Surface mounting
 Dimensions: Width: TBA mm, height: TBA mm Depth TBA mm (approx.)
 Power: 12VDC usually supplied from the battery backed system PSU

6.16.5 Connections

System Controller

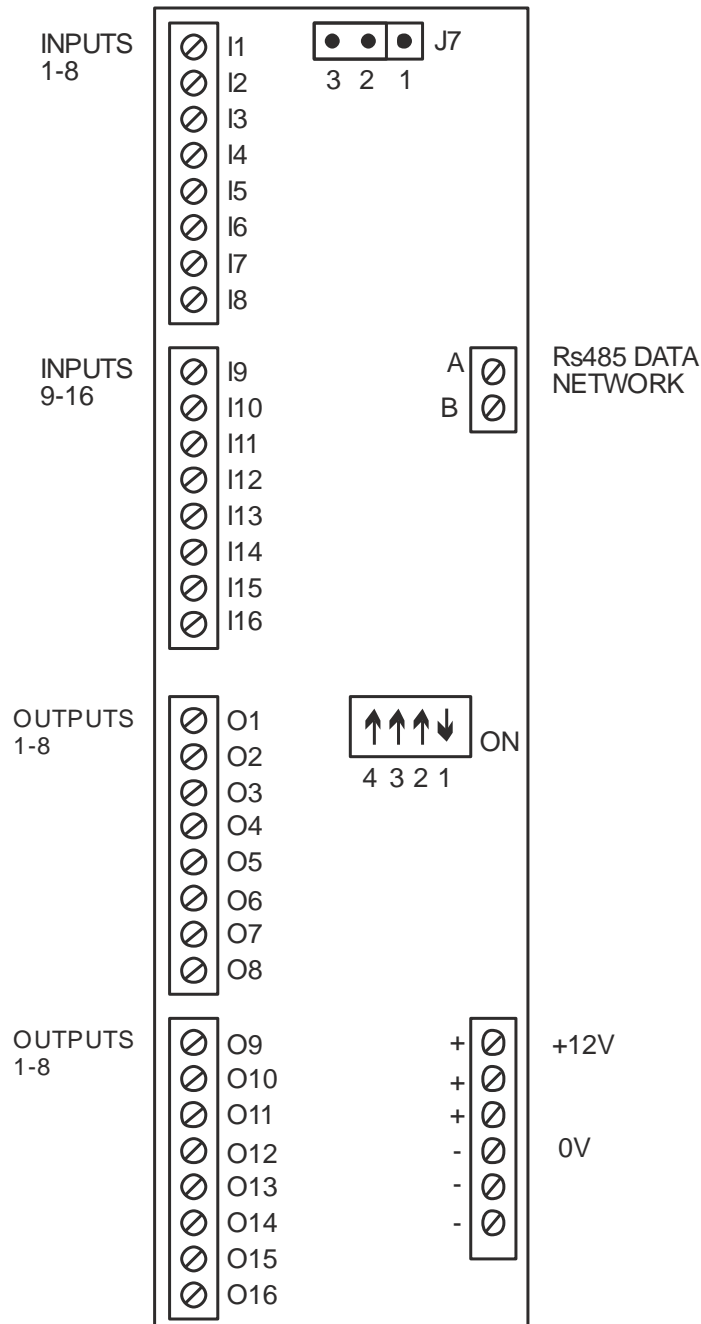

Fig 6:30 System Controller Connections

System controllers and remote indicator panels are networked using the AB terminals please refer to section 4 Extended Disabled Toilets Alarm Monitoring System above.

6.17 BATTERY BACKED SYSTEM PSU (P/N DT7500.00)



Fig 6:31 Battery Backed System Power Supply Unit

6.17.1 Features

- Fully enclosed surface mount unit
- Supplies battery backed power for disabled toilets system
- May not be required if compact disabled refuge EVC master station is used

6.17.2 Description

Battery backed system power supply units provides power for complete Disabled Toilets Alarm systems.

These units are usually installed near one of the system controllers.

These units are battery backed for continued operation in the event of a mains failure.

Usually only one PSU is required per disabled toilets system.

Battery backed system power supplies are supplied in fully enclosed surface mount enclosures.

6.17.3 Part Numbers

DT7500.00	Battery backed system PSU.
-----------	----------------------------

6.17.4 Specifications

Enclosure:	White painted mild steel
Mounting:	Surface mounting
Dimensions:	Width: TBA mm, height: TBA mm Depth TBA mm (approx.)
Power:	230 VAC

6.17.5 Connections

12 VDC Battery Backed Power Supply Unit

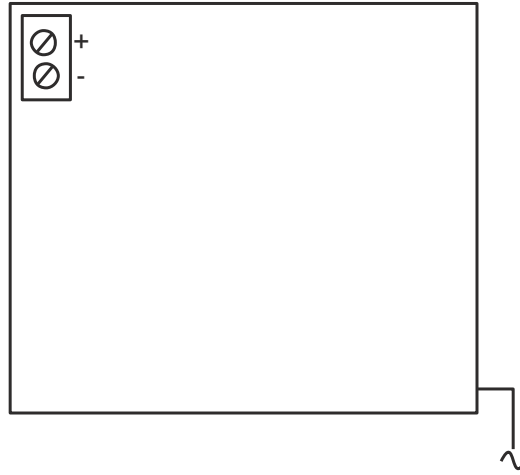

Fig 6:32 Battery Backed System Power Supply Connections

6.18 STANDARD NETWORK INTERFACE (P/N DT7501.01)



Fig 6:33 Standard Network Interface

6.18.1 Features

- Connects to standard IP networks
- Allows remote devices monitor alarm status
- Allows remote devices to mute alarm sounder(s)
- Ideal for BMS integration, alarm loggers etc.

6.18.2 Description

The standard network interface enables remote devices to monitor alarm status and mute alarm sounders using the standard Folknoll DT protocol. Special features / protocols for particular sites can be added on request.

The network interface can be connected to dedicated or existing network infrastructure as required and enables integration with site or offsite alarm monitoring, alarm logging or alarm control systems e.g. BMS.

6.18.3 Part Numbers

DT7501.01 Standard Network Interface

6.18.4 Specifications

Enclosure: White painted mild steel
Mounting: CS rail mounting
Dimensions: Width: TBA mm, height: TBA mm Depth TBA mm (approx.)
Power: 12 VDC usually supplied from system PSU

6.18.5 Connections

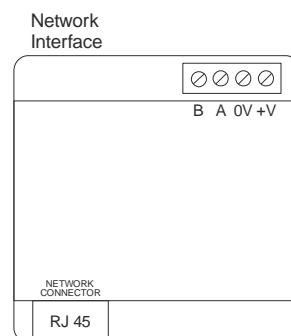

Fig 6:34 Standard Network Interface Connections

7 DISABLED TOILETS ALARM OPERATION

7.1 ACTIVATE AN ALARM

To call for assistance press and hold the emergency call button until the alarm sounds or pull and hold the pull cord, until the alarm sounds and the integral light is illuminated.

One or more of these devices should be mounted inside the toilet.



Fig 7:1 Example Pull Cords and Emergency Call Buttons

NOTE: To minimise accidental activation users must pull the cord or push the emergency call button for a minimum of 0.25 seconds to trigger an alarm.

7.2 ON ALARM

When an alarm is activated the local alarm annunciator (beacon/sounder) will be activated. The beacon will illuminate and the sounder will sound.

The alarm annunciator is usually mounted at a strategic location outside the toilet to attract attention. For example



Fig 7:2 Example Alarm Annunciators

Depending on site configuration annunciators may be combined with other units combined with other devices for example:-



Fig 7:3 Example Combined Alarm Annunciator

Annunciators may also be combine into and alarm panel, for example.



Fig 7:4 Example Multi Zone Alarm Annunciator

Respond to the alarm according to local regulations and procedures. When the alarm event has been resolved reset the alarm, please refer to section 7.3 Reset the Alarm below.

7.3 RESET THE ALARM

To reset an alarm, press and hold down the button or turn and hold the reset key on the local reset unit. Local and remote annunciated will be silenced and the local disabled toilet alarm system will be reset.

If the reset unit has been installed in a public area the reset function may be operated by a keyed switch to prevent unauthorised access.

If a key is required to reset the alarm please refer to local procedures for access to the key.

The reset button is usually located outside the toilet and may be combined with other devices for example:-



Fig 7:5 Example Reset Units

NOTE: To minimise accidental resets the reset button must be held down for a minimum of 0.25 seconds to reset the system.

7.4 REMOTE PANEL OPERATION

If remote indicator panel(s) are fitted these will also annunciate the alarm.

The integral sounder(s) will sound and an alarm message indicating the source of the alarm will be displayed.

The remote indicator panels are normally located in control or monitoring rooms to attract the attention of operator in the event of an alarm they may take the form of a stand-alone panel for example:-



Fig 7:6 Remote Indicator Panel

Or they could be built into a Disabled Refuge EVC Master Stations for example:-



Fig 7:7 Remote Indicator Panel Kit Mounted in Compact Disabled Refuge EVC Master Station

The remote indicator panel kit is the panel on the bottom right i.e.



Fig 7:8 Remote Indicator Panel Kit

If more than one alarm is active the display will scroll through a list of activated alarms.

If required for operational reasons remote indicator panel sounders can be muted by pressing the green mute button. Pressing the **MUTE** button will silence all remote indicator panel sounders on the system.

Respond to the alarm according to local regulations and procedures. When the alarm event has been resolved reset the alarm, please refer to section 7.3 Reset the Alarm above.

When all active alarms have been cancelled the remote panel indicator(s) will display **NO CALLS**.

NOTE: If a remote panel is fitted it cannot be used to reset an alarm. An operator must go to the source of the alarm to reset the alarm.

7.5 MANUAL SYSTEM TEST

If a remote panel kit is fitted it is possible to do a manual system check. Press and hold the test button. The system will run a self-diagnostics test. Any problems detected will be displayed on the LCD display.



Fig 7:9 Remote Indicator Panel Kit

Note the remote panel indicator kit is usually installed in the bottom right hand corner of a Disabled Refuge Master Station for example:-



Fig 7:10 Remote Indicator Panel Kit Mounted in Compact Disabled Refuge EVC Master Station

8 INSTALLATION

Fix the Disabled Toilets Alarm equipment.

Install appropriate cabling and test according to local regulations and procedures. For larger systems please consider signal loss etc. due to the length of cables etc. If in doubt please contact Folknoll.

Connect the equipment according to the termination diagram(s) provided by Folknoll.

Connect the system to the mains supply. This should be carried out by a skilled, competent and authorised person.

Power up the system.

Check supply voltages for all units is 12V+-10%.

Perform a routine maintenance check; please refer to section 9.1.1 Test Procedure below.

NOTE: The system is not fully operational; until the battery backup units are fully charged. Please allow time for charging to take place.

9 MAINTENANCE

9.1 ROUTINE MAINTENANCE

Each local disabled toilets alarm system should be routinely tested at a frequency determined by local regulations, conditions and procedures.

Arrange for the prompt repair of any faults revealed by the test procedure.

Replace the batteries in the backup unit every 2 years or as required by the battery manufacturers.

9.1.1 Test Procedure

Visit each local disabled toilet system in turn.

If the local alarm is activated respond to the alarm according to local regulations and procedures.

Check all equipment is present

Check for visible damage, e.g. pull cords, activators and annunciators are intact and there are no signs of water damage or other issues. If damage is suspected arrange for a repair according to local procedures.

Ensure that equipment and annotation is visible; remove obstructions/ stickers/paint/gum, etc. If the obstruction cannot be removed or the annotation has been erased arrange for a replacement according to local procedures.

Using each activator, (pull cord and or emergency switch etc.), in turn activate the alarm. If fitted check that the LEDs in the pull cord base (s) illuminate. Check that the local annunciator beacons are illuminated and their sounders are activated.

If fitted check that all remote indicator panel(s) responded correctly i.e. the sounder is activated and the correct message is displayed.

Check the mute button silences all the remote indicator panel sounders.

Reset the alarm using the local reset unit. Check that the pull cord LED(s) is/are extinguished, local annunciators are extinguished and silenced.

If fitted check that the remote panel has been silenced, its beacon extinguished and its LCD display returned to normal i.e. displays **SYSTEM OK**.

9.2 FAULT FINDING

9.2.1 Alarm cannot be Activated

Check power to the reset unit.

Check operation of the alarm activators.

Check cabling between the annunciator and the reset unit.

Check operation of the annunciator.

Check operation of the alarm reset unit.

9.2.2 Alarm Cannot be Reset

If the alarm remains activated after reset or the alarm becomes activated without pressing an emergency call button or pulling a pull cord this may indicate a cable break or equipment fault.

The activator circuit is wired as one or normal closed switches wired in series. Check for intermittent or permanent cable breaks between the reset unit and the activators; check the activator switches are normally closed.

NOTE: Emergency call buttons are fitted with anti tamper switches. If one or more emergency call buttons is fitted check for tampering, check for correct operation of the anti-tamper switches.

9.2.3 Remote Indicator Fail to Annunciate Alarms

If the remote indicator panel does not display **SYSTEM OK** check the power to the remote indicator panel, check the remote indicator panel.

If the remote indicator panel does display **SYSTEM OK** check the cabling between the remote indicator panel and the system controller(s), check power to the system controller(s), check the cabling between the stand-alone toilet systems and the system controllers(s).

9.2.4 Incorrect Alarm Message Displayed by Remote Indicator

Check that the stand-alone toilet system is wired into the correct system controller terminals.

Contact Folknoll for a replacement configuration.

10 USER NOTES

This section left blank for user notes.



Folknoll 

Old North Rd, Royston, HERTS, SG8 5DT
 Tel: 01763234567
 sales@folknoll.co.uk
 www.folknoll.co.uk



CONTRACTORS HEALTH & SAFETY ASSESSMENT SCHEME
 Accredited Contractor
 www.chas.gov.uk

