

Folknoll



Disabled Refuge EVC

RA7760.00

System Manual

DR 7700-000 SM6 V1.03 23/03/2012 Disabled Refuge EVC System Manual

Disabled Refuge EVC

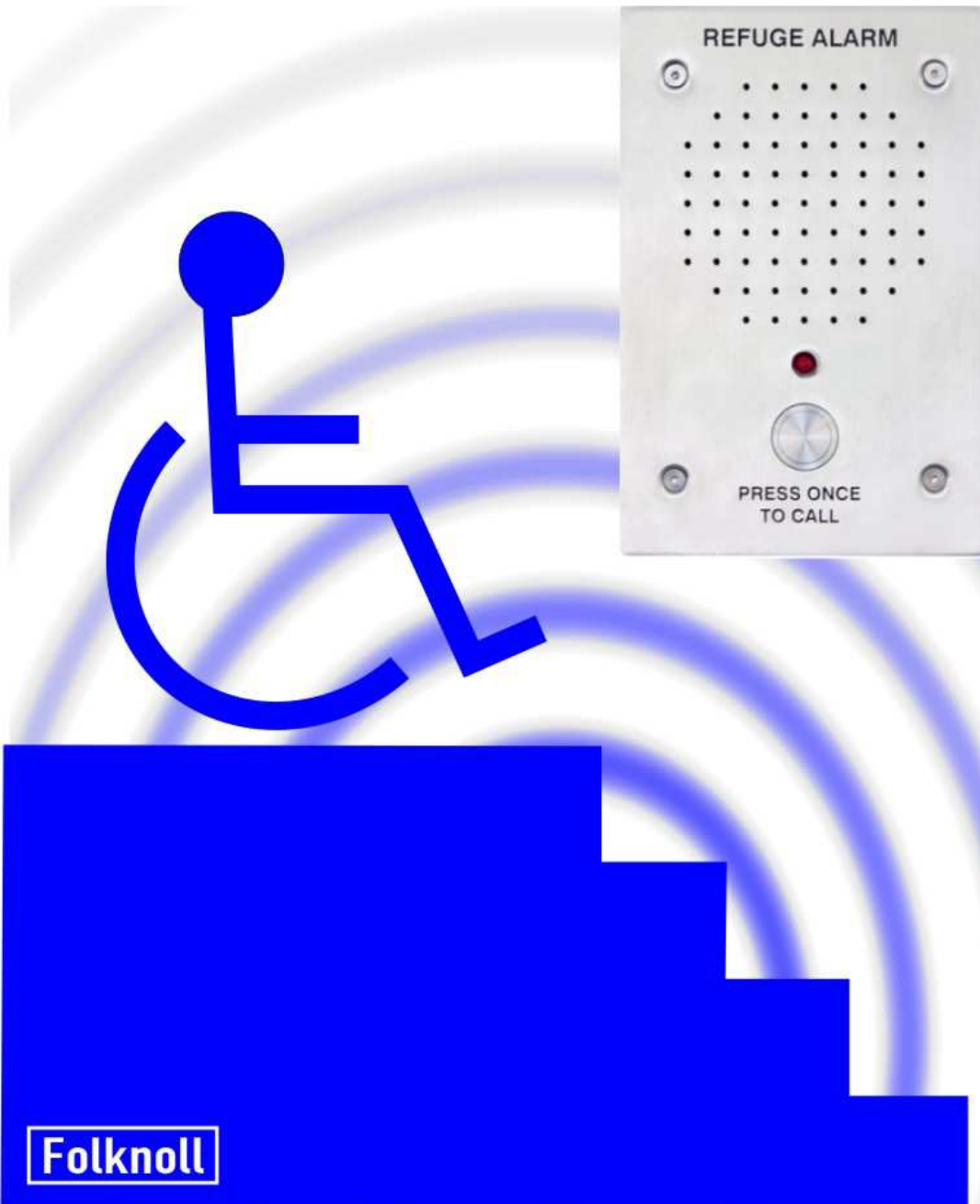

System Manual

ISSUE CONTROL

Issue	Date	Changes
1.00	08.12.2010	Original compact system manual.
1.01	03.08.2011	Enhanced outstation added.
1.02	10.08.2011	Enhanced outstation renamed pro outstation.
1.03	23.03.2012	Fire telephone outstation added. Ft120 cable added.

CONTENTS

1	INTRODUCTION.....	1
1.1	WHAT IS A DISABLED REFUGE EVC SYSTEM	1
1.2	FOLKNOLL DISABLED REFUGE SYSTEMS	1
1.2.1	Cabling	1
1.2.2	Compact Systems	1
1.2.3	Standard Systems	1
1.2.4	Outstations	2
1.2.5	Master Stations	2
1.2.6	Keyed Enable Switch	2
1.2.7	Remote Enable	2
1.2.8	Single Monitored Battery Backed PSU	2
1.2.9	Audio Path Fault Monitoring and Reporting	2
1.2.10	Remote Monitoring	2
1.2.11	Combined Refuge / Toilets / Fire Telephone Systems	2
1.3	DESIGNED FOR LIFE	3
1.4	COMPLETE SOLUTIONS	3
1.5	CUSTOM UNITS	3
1.6	CONTACT US	3
2	COMPACT DISABLED REFUGE EVC SYSTEMS	4
2.1	COMPACT SYSTEM FEATURES	5
2.2	COMPACT SYSTEM OUTSTATIONS	5
2.3	COMPACT SYSTEM MASTER STATIONS	6
2.4	COMPACT SYSTEM FAULT MONITORING	6
2.4.1	Compact System Audio Path Monitoring and Reporting	6
2.5	COMPACT SYSTEM BATTERY BACKED PSU	7
2.6	COMPACT SYSTEM CABLING	7
2.6.1	Compact System Cabling layout	7
2.6.2	Compact System Cabling Rules	7
2.6.3	Compact System Cable Connections	7
3	STANDARD DISABLED REFUGE EVC SYSTEMS.....	9
3.1	STANDARD SYSTEM FEATURES	10
3.2	STANDARD SYSTEM OUTSTATIONS	10
3.3	STANDARD SYSTEM MASTER STATIONS	11
3.4	STANDARD SYSTEM CONTROLLER	12
3.5	STANDARD SYSTEM FAULT MONITORING	13
3.5.1	Standard System Audio Path Monitoring and Reporting	13
3.6	STANDARD SYSTEM BATTERY BACKED PSU	13
3.7	STANDARD SYSTEM CABLING	14
3.7.1	Standard System Cabling layout	14
3.7.2	Standard System Cabling Rules	14
3.7.3	Standard System Cable Connections	14
4	AUDIO PATH TESTING	16
5	INSTALLATION	17
6	COMMISSIONING AND CONFIGURATION.....	18
6.1	OUTSTATION CONFIGURATION	18
6.2	SYSTEM CONTROLLER CONFIGURATION (STANDARD SYSTEM ONLY)	18
6.3	MASTER STATION CONFIGURATION	18

6.3.1	Master Station Keyboard Enable	18
6.3.2	Power Fault Monitoring	18
6.3.3	Master Station Initial Power up Test	20
6.3.4	Master Station Configuration Test	21
6.3.5	Master Station Factory Reset	21
6.4	AUDIO LEVEL AND OTHER ADJUSTMENTS	21
6.4.1	Master Station Audio Levels Adjustment	21
6.4.2	Outstations Audio Level Adjustment	21
6.5	MASTER STATION AUDIO PATH TESTS CONFIGURATION	22
7	OPERATION	23
7.1	ENABLING THE MASTER STATION	23
7.2	ACCEPTING CALLS FROM OUTSTATIONS	23
7.3	MAKING CALLS TO OUTSTATIONS	24
7.4	ALL CALLS	24
7.5	FIRE TELEPHONE OUTSTATIONS	25
7.6	FAULTS	25
7.7	MANUAL SYSTEM TEST (COMPACT SYSTEMS ONLY)	25
7.8	TO DISABLE THE MASTER STATION KEYBOARD	26
8	SYSTEM FAULTS.....	27
8.1	SUMMARY OF SYSTEM FAULT INDICATIONS	27
8.2	MAINS POWER FAIL	28
8.3	MAINS POWER AND PSU STANDBY BATTERY FAIL	28
8.4	CONFIGURATION BATTERY FAIL	28
8.5	SYSTEM POWERED WITH MASTER STATION DISABLED	28
8.6	AUDIO PATH FAULT	29
8.7	OUTSTATION CABLE DISCONNECTED	29
9	ROUTINE MAINTENANCE	30
9.1	STANDBY BATTERIES	30
9.2	VISUAL INSPECTION	30
9.2.1	Outstations	30
9.2.2	Master Station	31
9.2.3	Control Equipment (Standard System Only)	31
10	ROUTINE FUNCTIONAL TESTING	32
10.1	AUTOMATIC AUDIO PATH TESTING	32
10.2	USER CALL CHECK	32
10.3	OPERATOR CALL CHECK	32
10.4	ALL CALL CHECK	33
10.5	STANDBY OPERATION TEST	33
10.6	STANDBY TIME TEST	33
10.7	STANDBY BATTERY CHARGING VOLTAGE TEST	33
10.8	AUDIO PATH TESTS CHECK (MICROPHONE AND SPEAKER TESTS)	33
10.9	AUTOMATIC AUDIO PATH TESTING (MICROPHONE AND SPEAKER TESTS)	34
11	DISABLED REFUGE EVC COMPONENTS	35
11.1	EXTERNAL OUTSTATION (P/N RA7700.60)	35
11.1.1	Features	35
11.1.2	Description	35
11.1.3	Part Numbers	36
11.1.4	Specifications	36
11.1.5	Connections	36

11.2	INTERNAL OUTSTATION (P/N RA7700.30 AND RA7700.35)	37
11.2.1	Features	37
11.2.2	Description	37
11.2.3	Part Numbers	38
11.2.4	Specifications	38
11.2.5	Connections	38
11.3	PRO OUTSTATION (P/N RA7700.40 AND RA7700.45)	39
11.3.1	Features	39
11.3.2	Description	39
11.3.3	Part Numbers	40
11.3.4	Specifications	40
11.3.5	Connections	40
11.4	FIRE TELEPHONE OUTSTATION (P/N RA7700.50 AND RA7700.55)	41
11.4.1	Features	41
11.4.2	Description	41
11.4.3	Part Numbers	42
11.4.4	Specifications	42
11.4.5	Connections	42
11.5	COMPACT SYSTEM 5 WAY MASTER STATION (P/N RA7805.01)	43
11.5.1	Features	43
11.5.2	Description	43
11.5.3	Part Numbers	44
11.5.4	Specifications	44
11.5.5	Connections	44
11.5.6	Master Station Levels Adjustment	45
11.5.7	Outstation Levels Adjustment	45
11.6	COMPACT SYSTEM 10 WAY MASTER STATION (P/N RA7810.01)	47
11.6.1	Features	47
11.6.2	Description	47
11.6.3	Part Numbers	48
11.6.4	Specifications	48
11.6.5	Connections	48
11.6.6	Master Station Levels Adjustment	48
11.6.7	Outstation Levels Adjustment	49
11.7	STANDARD SYSTEM 5 WAY MASTER STATION (P/N RA7705.01 RA7705.05)	51
11.7.1	Features	51
11.7.2	Description	51
11.7.3	Part Numbers	52
11.7.4	Specifications	52
11.7.5	Connections	54
11.8	STANDARD SYSTEM 10 WAY MASTER STATION (P/N RA7710.01 RA7710.05)	55
11.8.1	Features	55
11.8.2	Description	55
11.8.3	Part Numbers	56
11.8.4	Specifications	56
11.8.5	Connections	58
11.9	STANDARD SYSTEM 15-WAY MASTER STATION (P/N RA7715.01 RA7715.05)	59
11.9.1	Features	59
11.9.2	Description	59
11.9.3	Part Numbers	60
11.9.4	Specifications	61
11.9.5	Connections	63
11.10	STANDARD SYSTEM 20-WAY MASTER STATION (P/N RA7720.01 RA7720.05)	64
11.10.1	Features	64
11.10.2	Description	64
11.10.3	Part Numbers	65

11.10.4	Specifications	66
11.10.5	Connections	68
11.11	STANDARD SYSTEM CONTROLLER (P/N RA7700.02)	69
11.11.1	Features	69
11.11.2	Description	69
11.11.3	Part Numbers	70
11.11.4	Specifications	70
11.11.5	Connections	70
11.11.6	Outstation Levels Adjustment	70
11.12	STANDARD SYSTEM BATTERY BACKED PSU (P/N RA7750.02, RA7750.04)	72
11.12.1	Features	72
11.12.2	Description	72
11.12.3	Indicators	73
11.12.4	Part Numbers	73
11.12.5	Specifications	73
11.12.6	Connections	73
11.12.7	Monitored PSU Schematic	74
12	APPENDIX A FIRETUF CABLES.....	75
13	APPENDIX B COMPACT SYSTEM MASTER STATION LABELS	77
13.1	COMPACT SYSTEM MASTER STATION 5 WAY REFUGE AREA LABEL	77
13.2	COMPACT SYSTEM MASTER STATION 10 WAY REFUGE AREA LABEL	78
14	USER NOTES	79

TABLE OF FIGURES

Fig 2:1 Typical Compact Disabled Refuge EVC System	4
Fig 2:2 Typical Outstations	5
Fig 2:3 Compact Master Stations	6
Fig 2:4 Typical Compact System Connections.....	8
Fig 3:1 Typical Disabled Refuge EVC System.....	9
Fig 3:2 Typical Outstations	10
Fig 3:4 Five Way Master Station	12
Fig 6:1 Table of Jumper Settings for 'Addressing' Standard System Controllers	18
Fig 6:2 Rear Panel of Compact Master Station Door	19
Fig 6:3 Location of Fault Monitoring Jumper.....	19
Fig 8:1 Table of System Fault Messages.....	27
Fig 11:1 External Outstation	35
Fig 11:2 Outstation Connections.....	36
Fig 11:3 Vandal Resistant Outstation.....	37
Fig 11:4 Outstation Connections.....	38
Fig 11:5 Pro Outstation	39
Fig 11:6 Pro Outstation Connections	40
Fig 11:7 Fire Telephone Outstation	41
Fig 11:8 Fire Telephone Outstation Connections	42
Fig 11:9 Compact System Five Way Master Station	43
Fig 11:10 Compact Master Station Connections.....	44
Fig 11:11 Rear Panel of Compact Master Station Door	45
Fig 11:12 Compact Master Station Main PCB Layout	46
Fig 11:13 Compact System Ten Way Master Station.....	47
Fig 11:15 Rear Panel of Compact Master Station Door	49
Fig 11:16 Compact Master Station Main PCB Layout	50
Fig 11:17 Standard System Five Way Master Station	51
Fig 11:18 Standard System Five Way Master Station Features	52
Fig 11:19 Standard System Five Way Master Station Dimensions	53
Fig 11:20 Standard Master Station Connections	54
Fig 11:21 Standard System Ten Way Master Station.....	55
Fig 11:22 Standard System Ten Way Master Station Features.....	56
Fig 11:23 Standard System Ten Way Master Station Dimensions.....	57
Fig 11:24 Standard Master Station Connections	58
Fig 11:25 Standard System Fifteen Way Master Station	59
Fig 11:26 Standard System Fifteen Way Master Station Features	61
Fig 11:27 Standard System Fifteen Way Master Station Dimensions.....	63
Fig 11:28 Standard Master Station Connections	63
Fig 11:29 Standard System Twenty Way Master Station.....	64
Fig 11:32 Standard Master Station Connections	68
Fig 11:33 Standard System Controller	69
Fig 11:34 Standard System Controller Connections	70
Fig 11:35 Standard System Controller PCB Layout	71

Fig 11:36 Standard System Power Supply Unit.....	72
Fig 11:37 Standard PSU Connections.....	73
Fig 11:38 PSU General Layout.....	74
Fig 13:1 Compact System Master Station 5 Way Refuge Area Label.....	77
Fig 13:2 Compact System Master Station 10 Way Refuge Area Label.....	78

1 INTRODUCTION

This document is the System Manual for Folknoll compact and standard range of Disabled Refuge EVC systems.

The Folknoll Disabled Refuge EVC series is a range of easy to install, easy to configure and easy to operate equipment, designed to enable you and your clients to install BS5839-9 compliant vandal resistant disabled refuge EVC systems.

1.1 WHAT IS A DISABLED REFUGE EVC SYSTEM

In the event of an emergency disabled people make their way to disabled refuge areas to wait for rescue. The Disabled Refuge EVC system is used to contact the evacuation organiser to request assistance. The evacuation organiser uses the Disabled Refuge EVC system to instruct, inform and reassure people waiting in the disabled refuge areas.

1.2 FOLKNOLL DISABLED REFUGE SYSTEMS

Folknoll Disabled Refuge EVC systems comprise a number of outstations located in disabled refuge areas, control equipment and a master station located in the control or operations area. A range of options are available to construct a system suit your requirements. All Folknoll Disabled Refuge EVC systems have a key enabled switch, integral fault monitoring, and can be powered from a battery backed power supply providing at least 24 hours standby and 30 minutes operation in the event of a power fail.

1.2.1 Cabling

At Folknoll all equipment is designed by experience engineers for ease of installation and operation. In particular the designers of Disabled Refuge EVC systems have taken into account the BS requirement to use larger fire resistant cabling, providing cable termination within enclosures, allowing room for larger glands and avoiding the need for additional junction boxes.

1.2.2 Compact Systems

For smaller systems, with 10 refuge areas or less, Folknoll offer their cost effective compact system. Compact system installation costs are reduced without compromising functionality by building the system controller and a battery backed PSU into the compact system master station. Outstations are cabled directly to the compact system master station. The compact system master stations are the same size and have similar build quality to standard fire alarm panels.

1.2.3 Standard Systems

For larger systems, requiring more facilities and options Folknoll offer their more flexible standard system. Outstations are connected to daisy chained system controllers allowing more cabling options. Up to four system controllers can be connected into the system allowing a larger number of outstations. Standard system master stations are vandal resistant offering a more robust solution for more exposed control areas.

1.2.4 Outstations

Folknoll offer surface or flush mount vandal resistant and surface mount IP65 external outstations for used with compact or standard Disabled Refuge EVC systems.

1.2.5 Master Stations

Folknoll offer a range of 2-off fire panel sized compact system master stations with integral system controller and PSU for smaller systems, and 4-off vandal resistant standard system master stations for larger systems.

1.2.6 Keyed Enable Switch

All compact and standard Folknoll Disabled Refuge EVC system master stations have a keyed enable switch which can be used to prevent unauthorised access.

1.2.7 Remote Enable

All compact and standard Folknoll Disabled Refuge EVC systems have a remote enable input. This allows a remote device such as a management system or fire alarm system to enable the master station irrespective of the state of the keyed enable switch.

1.2.8 Single Monitored Battery Backed PSU

All Folknoll compact and standard Disabled Refuge EVC systems can be powered from a single battery backed PSU. In the event of a mains failure the backup unit is capable of providing at least 24 hours standby and 30 minutes operation. The mains supply is monitored and supply failures are reported by the master station.

1.2.9 Audio Path Fault Monitoring and Reporting

Compact and standard Folknoll Disabled Refuge EVC systems offer audio path monitoring and reporting. Audio tones are sent to outstation speakers, received by outstation microphones and compared. Any discrepancies caused for example by chewing gum covering the microphone hole are reported by the master station.

Compact and manual audio path testing can be triggered by external timers or management systems. Audio path test fail output(s) are available to activate external devices or warning management systems.

Compact systems can have a manual test switch and internal timer.

1.2.10 Remote Monitoring

Folknoll offer closing contact, serial and IP interfaces for integration with remote systems, e.g. BMS, alarm gathering etc. helping to provide an integrated solution for your needs.

1.2.11 Combined Refuge / Toilets / Fire Telephone Systems

Folknoll disabled refuge EVC systems can be combined with disabled toilet alarms and fire telephones to produce a cost effective solutions for your sites.

1.3 DESIGNED FOR LIFE

As with all Folknoll products, the Disabled Refuge EVC system have been designed for easy installation, simple configuration, straightforward operation, excellent testing facilities, low maintenance and high reliability.

1.4 COMPLETE SOLUTIONS

Folknoll are happy to assist in specifying equipment, configuring systems and providing connection diagrams.

1.5 CUSTOM UNITS

Folknoll is a customer focused company. If you require special software features, custom made units or larger systems, then please contact Folknoll to discuss your requirements.

1.6 CONTACT US

For further information about Folknoll Disabled Refuge EVC systems or any other Folknoll products please contact us on **+44 (0) 1763 234567**, email us at sales@folknoll.co.uk, or visit our website at www.folknoll.co.uk.

2 COMPACT DISABLED REFUGE EVC SYSTEMS

For smaller sites with 10 or less refuge areas, Folknoll offer their cost effective compact Disabled Refuge EVC system, where vandal resistant master stations are not required.

Compact system installation costs are reduced without compromising functionality by building the system controller and a battery backed PSU into the compact system master station. Terminals are provided within all equipment for cable terminations and space is allowed for glanding of larger fire resistant cable types to comply with BS requirements. The equipment count is reduced and cabling simplified.

Compact system master stations are designed to match stand fire alarm size and quality and are suitable for mounting in similar secure areas.

For a typical compact system please refer to the figure below:-

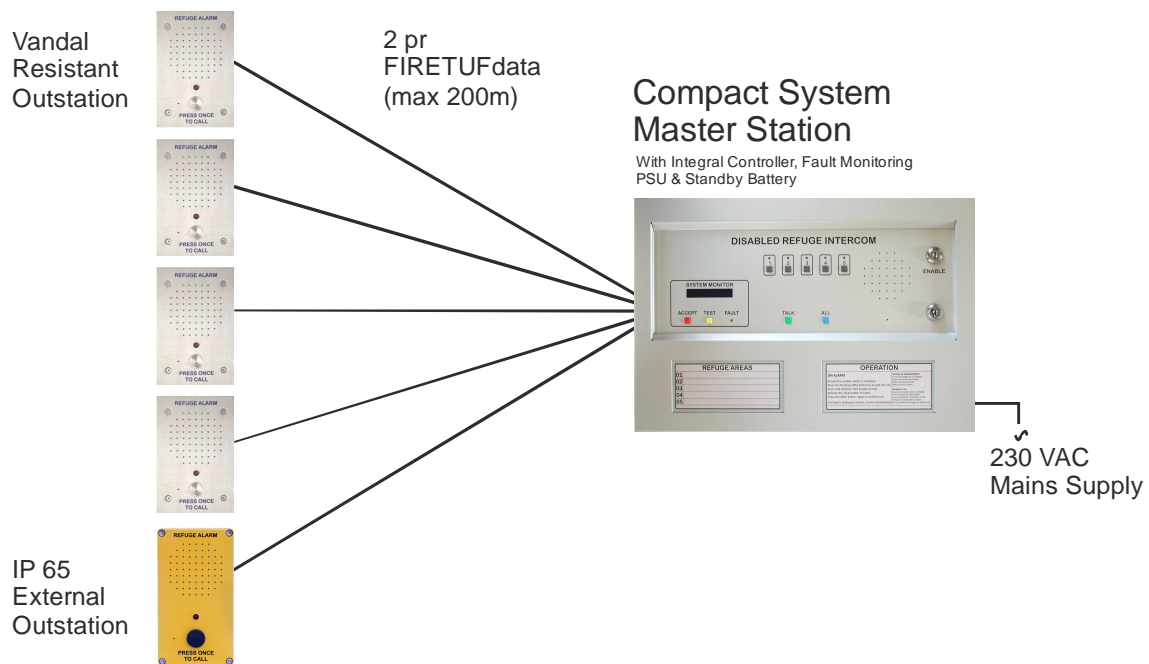

Fig 2:1 Typical Compact Disabled Refuge EVC System

2.1 COMPACT SYSTEM FEATURES

- Cost effective solution with reduced equipment count and simplified cabling
- Compatible with all Folknoll Disabled Refuge EVC outstations
- Adjustable microphone and speaker volumes
- Master stations and outstations have maximum audio out of 80 dB (for noisy environments)
- Range of mild steel master stations with built in controller and PSU
- All compact system master stations match standard fire panel size and quality.
- Fault monitoring and reporting with output for BMS etc.
- Battery backed PSU, 24 hours standby and 30 minutes operation
- Connection termination within equipment, provision for larger cable types

2.2 COMPACT SYSTEM OUTSTATIONS



Fig 2:2 Typical Outstations

Outstations are located in refuge areas and used by users to communicate with evacuation organisers.

Folknoll offer a number of outstations suitable for use with the compact disabled refuge EVC system, including the bright yellow RA7700.60 IP65 external outstation, the vandal resistant stainless steel RA7700.30 and RA7700.35 internal outstations, the RA7700.40 and RA7700.45 pro-outstations, the RA7700.45 and RA7700.55 fire telephone outstations.

Each outstation has an integral microphone and speaker, a large **CALL** button and a call progress LED.

The fire telephone outstation also has an internal handset and can be operated hands free or in telephone mode.

Microphone and speaker volume can be adjusted with a maximum audio output of 80 dB for use in noisy environments.

Please refer to section 11 Disabled Refuge EVC Components.

2.3 COMPACT SYSTEM MASTER STATIONS



Fig 2:3 Compact Master Stations

Master stations are located in the control or operations area and used by the evacuation organizer to communicate with all system users.

Compact system master stations comprise an operator control panel, a system controller and battery backed PSU.

Microphone and speaker volume can be adjusted with a maximum output of 80 dB for use in noisy environments.

All compact system master stations are designed to match standard fire panel size and quality.

Folknoll offer the choice 5 and 10 refuge area mild steel compact system master stations with system control, PSU, standby batteries and cable termination.

- RA7805.01 for compact systems with up to 5-off outstations
- RA7810.01 for compact systems with up to 10-off outstations

To aid operators compact master stations are fitted with operating instructions and a card for installers to add their own refuge area descriptions.

2.4 COMPACT SYSTEM FAULT MONITORING

Compact system power fail, audio path and other faults are monitored and reported by the compact system master station, please refer to section 8 System Faults.

2.4.1 Compact System Audio Path Monitoring and Reporting

Compact Folknoll Disabled Refuge EVC systems have automatic audio path monitoring and reporting. Audio tones are sent to outstation speakers, received by outstation microphones and compared. Any discrepancies are reported by the compact master station; please refer to section 8 System Faults.

Compact system master stations have a manual **TEST** button and internal timer which may be configured to trigger audio path testing.

Audio path testing may also be triggered by external devices such as a timer or management system.

Compact system audio path testing can also be triggered by applying a short to a connector on the compact master station.

An audio path test fail output is available to activate an external indicator or to interface with an external monitoring system.

Please refer to section 11.5 Compact System 5 Way Master Station (P/N RA7805.01) or section 11.6 Compact System 10 Way Master Station (P/N RA7810.01).

NOTE: During testing outstations will emit audio tones. Testing should be timed to minimise inconvenience.

2.5 COMPACT SYSTEM BATTERY BACKED PSU

All Folknoll compact and standard Disabled Refuge EVC systems can be powered from a single battery backed PSU. In the event of a mains failure the backup unit is capable of providing at least 24 hours standby and 30 minutes operation. The mains supply is monitored and supply failures are reported by the master station.

The compact system PSU is built into the compact system master station, please refer to section 11.5 Compact System 5 Way Master Station (P/N RA7805.01) and section 11.6 Compact System 10 Way Master Station (P/N RA7810.01).

2.6 COMPACT SYSTEM CABLING

Outstations are star wired to the compact system master station, enabling simple cost effective installation.

NOTE: all type cables should conform to the relevant British Standards, fire resistant cabling may be required e.g. Ft120 or FIRETUFdata, please refer to section 12 APPENDIX A FIRETUF Cables.

2.6.1 Compact System Cabling layout

- Each outstation is connected by a shielded 2 pair cable to the master station.
- The master station is connected to mains supply.

2.6.2 Compact System Cabling Rules

- No termination resistors are required.
- Assuming FIRETUFdata cable is used the maximum length of cable between each outstation and the master station is 200m.

2.6.3 Compact System Cable Connections

All connection is via terminal block located within the equipment, 'knockouts' have been provided for cable entry. Folknoll's design has allowed sufficient room for glands for larger fire resistant cable types to comply with BS requirements.

Please refer to the drawing below:

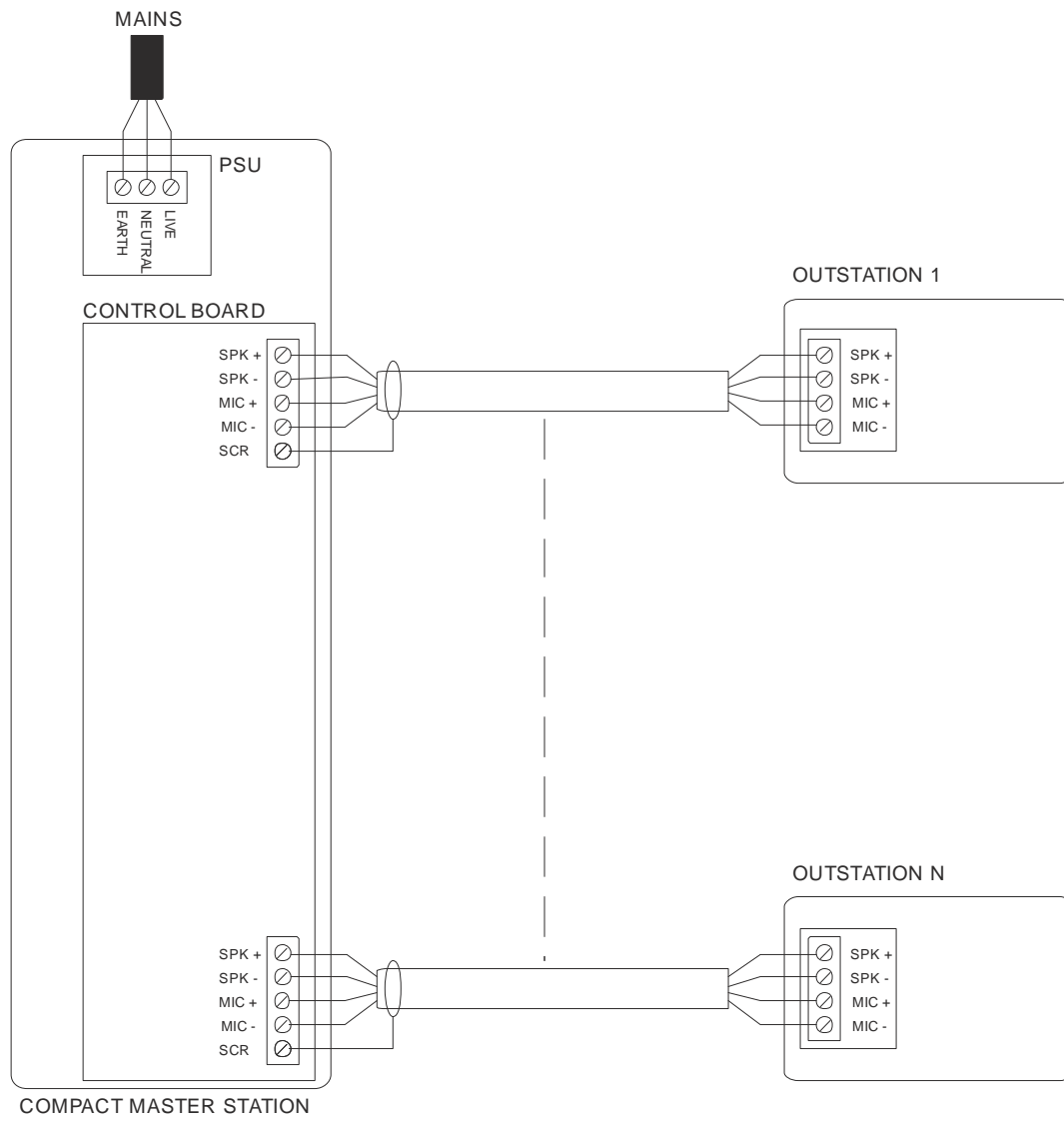

Fig 2:4 Typical Compact System Connections

3 STANDARD DISABLED REFUGE EVC SYSTEMS

The standard Disabled Refuge EVC system offers a more flexible solution with more outstations, additional cabling options and a range of more robust monitoring stations.

Standard systems are wired in zones with separate controllers, increasing the number of outstations and increasing the options for cable routing. Terminals are provided within all equipment for cable terminations and space is allowed for glanding of larger fire resistant cable types to comply with BS requirements.

Standard system master stations are designed to be vandal resistant and are suitable for mounting more exposed areas.

The figure below shows a typical standard system:-

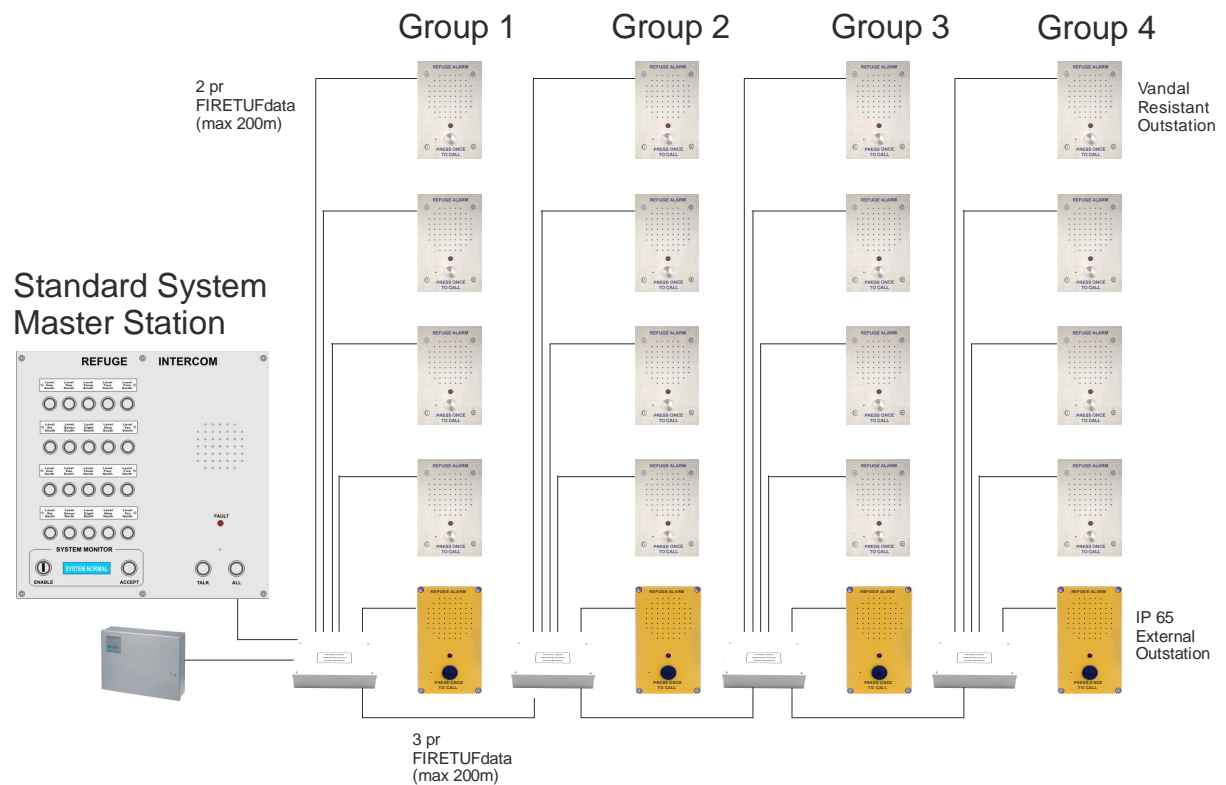

Fig 3:1 Typical Disabled Refuge EVC System

3.1 STANDARD SYSTEM FEATURES

- Compatible with all Folknoll Disabled Refuge EVC outstations
- Adjustable microphone and speaker volumes
- Master stations and outstations have maximum audio out of 80 dB (for noisy environments)
- Range of stainless steel master stations
- Fault monitoring and reporting with outputs for BMS etc.
- Battery backed PSU, 24 hours standby and 30 minutes operation
- Connection termination within equipment, provision for larger cable types
- Separate system controllers and PSU; allows more outstations; allows more cabling options

3.2 STANDARD SYSTEM OUTSTATIONS



Fig 3:2 Typical Outstations

Outstations are located in refuge areas and used by users to communicate with evacuation organisers.

Folknoll offer a number of outstations suitable for use with the standard disabled refuge EVC system, including the bright yellow RA7700.60 IP65 external outstation, the vandal resistant stainless steel RA7700.30 and RA7700.35 internal outstations, the RA7700.40 and RA7700.45 pro-outstations, the RA7700.50 and RA7700.55 fire telephone outstations.

Each outstation has an integral microphone and speaker, a large **CALL** button and a call progress LED.

The fire telephone outstation also has an internal handset and can be operated hands free or in telephone mode.

Microphone and speaker volume can be adjusted with a maximum audio output of 80 dB for use in noisy environments.

Please refer to section 11 Disabled Refuge EVC Components.

3.3 STANDARD SYSTEM MASTER STATIONS



Fig 3:3 Standard Master Stations

Folknoll offer a choice of 5, 10, 15, and 20 refuge area vandal resistant stainless standard system master stations.

- RA7705.01/05 for standard systems of up to 5-off outstations
- RA7710.01/05 for standard systems of up to 10-off outstations
- RA7715.01/05 for standard systems of up to 15-off outstations
- RA7720.01/05 for standard systems of up to 20-off outstations

The standard master stations are designed for mounting in more exposed areas with stainless steel enclosures, vandal resistant switches and customisable engraved refuge area names.

Microphone and speaker volume can be adjusted with a maximum output of 80 dB for use in noisy environments.

All standard system master stations have the same functionality with different fascia to depending on the number of outstation buttons. All standard system master stations can be flush or surface mounted to suite your application.

Folknoll can provide bespoke engraved outstation annotation for the master station to give meaningful identifications for your outstations. E.g. **'Lower lift lobby'** instead of **'SUB 1'**. Please contact Folknoll for more details. A five way standard system master station is shown below:-

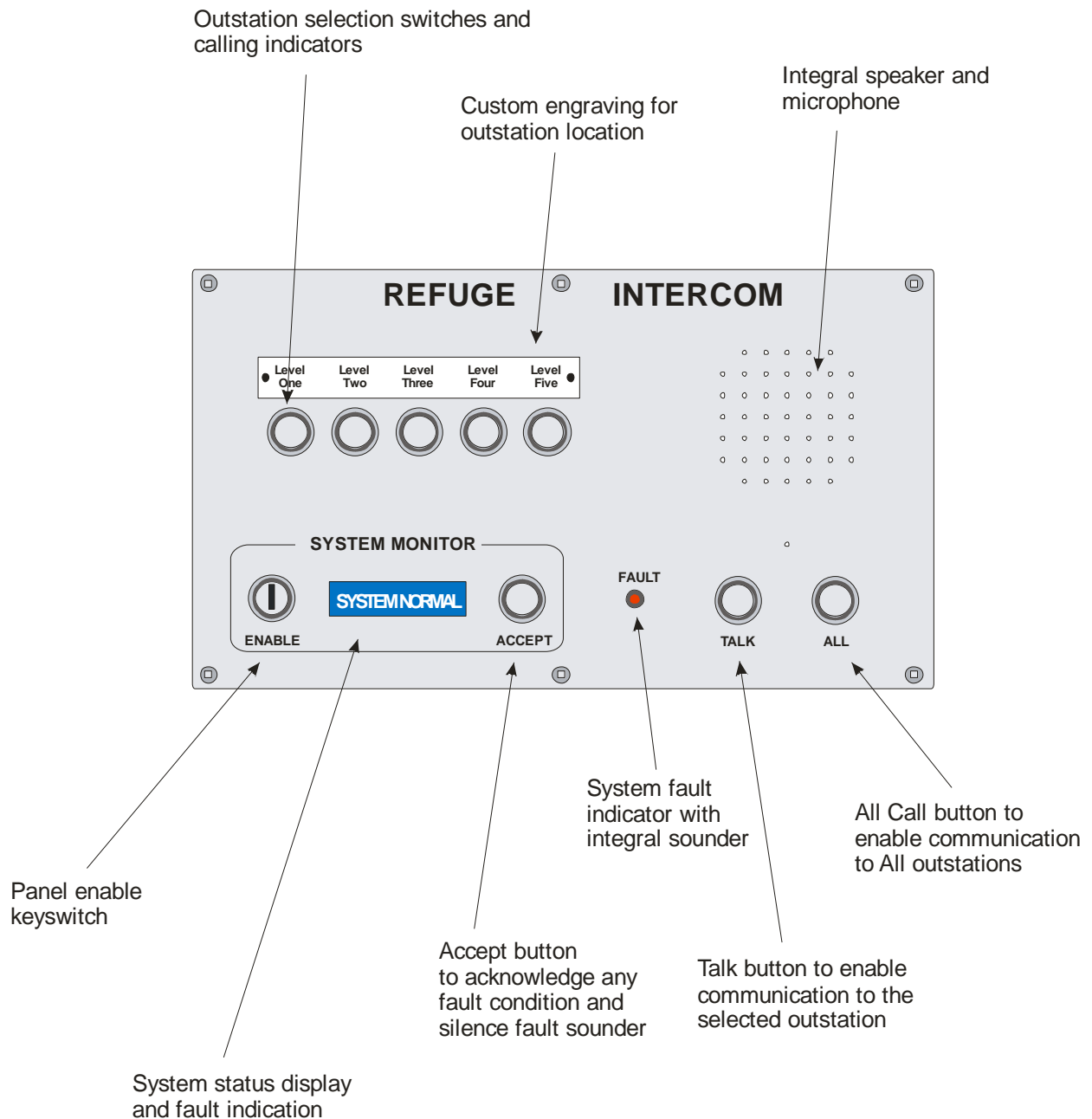

Fig 3:4 Five Way Master Station

For more information about other Folknoll Disabled Refuge EVC standard system master stations please refer to section 11 Disabled Refuge EVC Components.

3.4 STANDARD SYSTEM CONTROLLER

The standard system controller interfaces up to 5-off outstations onto the system. Each controller is addressable to identify which group of outstations it controls. The controller provides individual microphone volume and speaker volume for each of its outstations. The controller have a test input to trigger audio path testing of its outstations and has a fault output relay to drive an external fault indicator or monitoring system.

For more information about Folknoll Disabled Refuge EVC system controllers please refer to section 11 Disabled Refuge EVC Components.

3.5 STANDARD SYSTEM FAULT MONITORING

Standard faults are reported by the standard system master station; please refer to section 8 System Faults.

3.5.1 Standard System Audio Path Monitoring and Reporting

Standard Folknoll Disabled Refuge EVC systems have audio path monitoring and reporting. Audio tones are sent to outstation speakers, received by outstation microphones and compared. Any discrepancies are reported by the standard system compact master station; please refer to section 8 System Faults.

Standard system controllers will test its own outstations. To trigger a test apply a short to connector J11 on each standard system controller. Each system controller can be triggered separately or simultaneously as required. Please refer to section 11.11 Standard System Controller (P/N RA7700.02).

NOTE: Each system controller tests its own outstations. To test the entire system the short must be applied to all system controllers.

If required audio path testing can be automated by connecting the standard system controller inputs to an external timer or management system.

NOTE: During testing outstations will emit audio tones. Testing should be timed to minimise inconvenience.

Each standard system controller has a fault output relay. This can be used to activate an external indicator or management system. Connection is made to connect to relay output J6 please refer to section 11.11 Standard System Controller (P/N RA7700.02).

NOTE: Each system controller sets an output depending on the results of testing its own outstations. To detect all outstation fails the output from all system controllers must be monitored.

3.6 STANDARD SYSTEM BATTERY BACKED PSU

All Folknoll compact and standard Disabled Refuge EVC systems can be powered from a single battery backed PSU. In the event of a mains failure the backup unit is capable of providing at least 24 hours standby and 30 minutes operation. The mains supply is monitored and supply failures are reported by the master station.

Standard system power is derived from the standard system PSU and standby battery set. This combination will provide power for up to 20-off outstations, 4-off system controllers and one master station.

For more information about Folknoll Disabled Refuge EVC PSUs and Battery Sets please refer to section 11 Disabled Refuge EVC Components.

3.7 STANDARD SYSTEM CABLING

Outstations are star wired to system controllers which are daisy chained to the master station. Standard systems can be star wired back to a central point or to star wired distributed collection points, enabling a variety of cabling options, particularly useful when retrofitting systems to existing buildings.

NOTE: all type cables should conform to the relevant British Standards, fire resistant cabling may be required e.g. Ft120 or FIRETUFdata, please refer to section 12 APPENDIX A FIRETUF Cables.

3.7.1 Standard System Cabling layout

- Each outstation is connected by a shielded 2 pair cable to its system controller.
- The master station and all of the system controllers are looped together by a 3 pair cable.
- The first system controller is connected to the PSU by 4 cores
- The PSU is connected to a mains supply.

3.7.2 Standard System Cabling Rules

- No termination resistors are required.
- Assuming FIRETUFdata cable is used the maximum length of cable between each outstation and its system Controller is 200m.
- Assuming FIRETUFdata cable is used the maximum length of cable between each system Controller is 200m.
- Assuming FIRETUFdata cable is used the maximum length of cable between the first system Controller and the master station is 200m.

3.7.3 Standard System Cable Connections

All connection is via terminal block located within the equipment, 'knockouts' have been provided for cable entry. Folknoll's design has allowed sufficient room for glands for larger fire resistant cables types to comply with BS requirements.

Please refer to the Drawing below:

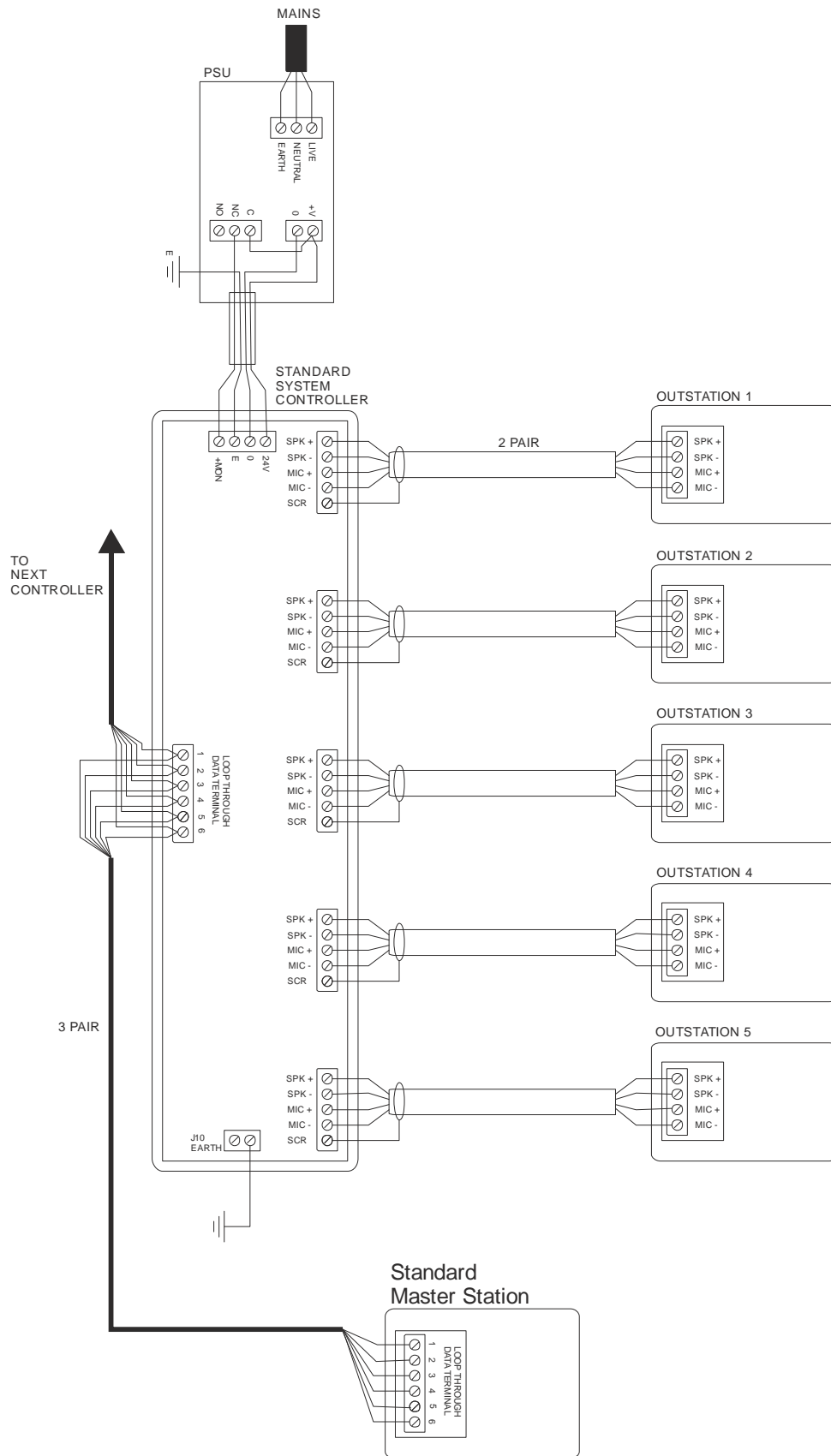

Fig 3:5 Typical Standard System Connections

4 AUDIO PATH TESTING

The Folknoll disabled refuge EVC system has an automatic audio path testing feature. Audible tones are sent to each outstation speaker in turn and detected by the outstation's microphone. The outgoing and incoming signals are compared to verify the complete electrical and mechanical audio path between the outstation user and the control system.

Audio path testing is automatically triggered by a configurable internal timer either located near the main system controller (standard system) or inside the master station (compact system) please refer to section 6.5 Master Station Audio Path Tests Configuration.

Audio path testing may also be triggered manually as required from the master station (compact systems) please refer to section 7 Operation.

Audio path testing may be triggered by remote devices such as BMS. Inputs are available on system controllers (standard system) and the master station (compact system), please refer to section 11 Disabled Refuge EVC Components.

Any faults detected are reported to the operator by the system master station; please refer to section 8 System Faults.

Faults are also indicated for remote devices by outputs on the appropriate system controller (standard system) or the master station (compact system), please refer to section 11 Disabled Refuge EVC Components.

5 INSTALLATION

Mount the equipment and pull the required cables, please refer to section 2 Compact Disabled Refuge EVC Systems or section 3 Standard Disabled Refuge EVC Systems as appropriate

Terminate the cables please refer to section 2.6.3 Compact System Cable Connections or section 3.7.3 Standard System Cable Connections as appropriate.

Do not power up, (please refer to Section 6 Commissioning below).

NOTE: Cable and equipment should be installed in accordance with the current British Standards.

6 COMMISSIONING AND CONFIGURATION

This section describes system commissioning, after commissioning the system should be tested as described in section 10 Routine Functional Testing

6.1 OUTSTATION CONFIGURATION

Outstation address configuration is not required, outstation IDs are depend on the system port to which they are connected. Connected outstation are detected during the master station configuration process to section please refer to section 6.3.3 Master Station Initial Power up Test

Outstation speaker and microphone audio levels are set in the system controller or compact master station depending on system design. Audio level adjustment can only be carried out after the master station has been configured, please refer to section 6.3.3 Master Station Initial Power up Test and section 6.4.2 Outstations Audio Level Adjustment.

6.2 SYSTEM CONTROLLER CONFIGURATION (STANDARD SYSTEM ONLY)

All system controllers must be “addressed” to identify which group of outstations it is controlling. The controller is addressed using jumpers J8 (6-10) and J13 (11-15), please refer to section 11.11 Standard System Controller (P/N RA7700.02). The jumpers should be set according to the following table:-

	SYSTEM CONTROLLER FOR OUTSTATIONS 1-5	SYSTEM CONTROLLER FOR OUTSTATIONS 6-10	SYSTEM CONTROLLER FOR OUTSTATIONS 11-15	SYSTEM CONTROLLER FOR OUTSTATIONS 15-20
J8 (6-10)	UNLINKED	LINKED	UNLINKED	LINKED
J13 (11-15)	UNLINKED	UNLINKED	LINKED	LINKED

Fig 6:1 Table of Jumper Settings for 'Addressing' Standard System Controllers

6.3 MASTER STATION CONFIGURATION

Please refer to section 11 Disabled Refuge EVC Components to familiarise yourself with the layout of your master station keyboard.

6.3.1 Master Station Keyboard Enable

The system master station is fitted with a keyed enable switch to enable/disable the master panel buttons (keyboard), please refer to section 11 Disabled Refuge EVC Components. This switch is used to prevent unauthorized persons operating the system and/or to enable the system in the event of emergency. Ensure that this switch is set in the enable position, i.e. turn the key clockwise before applying power to the system.

NOTE: On a compact master station the upper keyhole is used to enable the master station. The lower keyhole is used to unlock and the enclosure door.

6.3.2 Power Fault Monitoring

Master stations are fitted with a battery backed power fault monitoring circuit. If a power fault occurs the master station will continuously emit 2 short bleeps and one long bleep, the fault LED will flash and the system status display will be off.

Power fault monitoring is disabled for shipping and installation. Before powering up a newly installed system enable the fault monitoring.

Enabling Compact Master Station Fault Monitoring

To enable compact system power fault monitoring set the master station fault switch (switch 2) to on. Switch 2 is located on the rear of the compact master station door, please see below:-



Fig 6:2 Rear Panel of Compact Master Station Door

Enabling Standard Master Station Fault Monitoring

To enable standard system power fault monitoring link (insert a jumper) across J14. J14 is located on the rear of the master station PCB, please see below:-

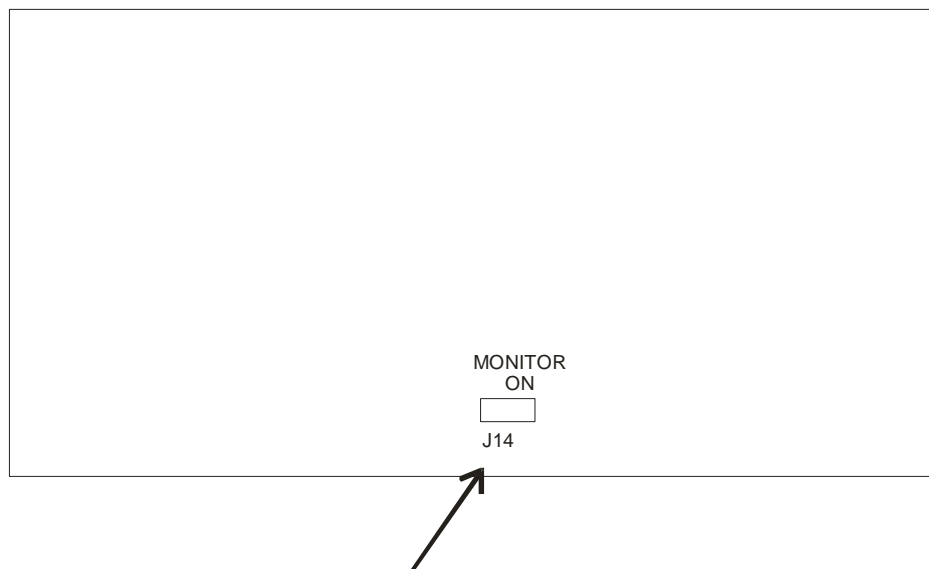

**Monitor Enable Jumper
(Rear of Master Station PCB)**

Fig 6:3 Location of Fault Monitoring Jumper

After enabling the master station fault monitoring the system will report power fault until the system has been powered up.

6.3.3 Master Station Initial Power up Test

Power up the system, if the system status display shows **PLEASE ENABLE**, enable the master station keyboard using the keyed enable switch, please refer to section 6.3.1 Master Station Keyboard Enable.

The master station system status display will show **POWER UP TEST**. After a short interval the display will change to **LED TEST** and the master station LEDs will flash, check that all of the buttons flash.

If the system has already been configured the master station will attempt to verify the configurations and a fault message(s) will be displayed e.g. **SUB 01 AUD FAULT**, please refer to section 6.3.4 Master Station Configuration Test.

If this system has no configuration the system status display will scroll **DETECT SUBS / PRESS ACCEPT**. The system is requesting permission to scan for outstations (SUBS). Press the **ACCEPT** button whilst **ACCEPT** is shown on the system status display to start the system scan.

The system status display will show **PLEASE WAIT** whilst the system is scanned.

When scanning is completed the system status display will scroll through a list of outstations detected followed by **PRESS ACCEPT**

If the list of outstations is incorrect there may be a cabling fault, outstation fault or similar, resolve the issue(s) and power cycle the system, please refer to section 8 System Faults.

If the list of outstations is correct press the **ACCEPT** button whilst **ACCEPT** is shown on the system status display.

The system will now perform an audio path test, please refer to Section 10.8 Audio Path Tests. The system status display will scroll **AUDIO TEST / PLEASE WAIT**. When the test is completed the system will illuminate the buttons corresponding to the outstations that failed the test and the system status display will scroll **NOT FITTED? / IS THIS CORRECT / YES / NO**. Check that the buttons illuminated as **NOT FITTED** are as expected.

If the pattern of LEDs is correct all configured outstations have passed the audio path tests. If the pattern of LEDs is incorrect, there may be a cabling fault, outstation fault or similar.

To cancel system operation select **NO** by pressing the **ACCEPT** button when **NO** is displayed, the system status display will change to **SYSTEM RESET**, resolve any issue(s) and power cycle the system, please refer to section 8 System Faults.

To continue operation select **YES** by pressing **ACCEPT** when **YES** is displayed.

If the pattern of LEDs is incorrect continued operation is possible but the system will report the fault(s), please refer to section 8 System Faults below.

If the pattern of LEDs is correct the system outstations have passed the audio path test select **YES** by pressing the **ACCEPT** button when **YES** is displayed and the system is now ready for use. The system status display will show **PANEL ENABLED**.

If required by local operating procedures disable the master station keyboard using the keyed enable switch the system status display will change to **SYSTEM NORMAL**.

6.3.4 Master Station Configuration Test

If the system powered up and the system has already been configured the master station will attempt to verify the configurations and a fault message(s) will be displayed e.g. **SUB 01 AUD FAULT**. Trigger a system test by pressing the **TEST** button on the master station, please refer to section 7.7 Manual System Test (Compact Systems Only). The system will perform audio paths test. If the result of the test matches the stored configuration then normal operation will resume. The system status display will show **PANEL ENABLED**. If required disable the master station using the keyed enabled switch please refer to section 7.8 To Disable the Master Station Keyboard.

The configuration can be erased by performing a factory reset please refer to section 6.3.5 Master Station Factory Reset.

6.3.5 Master Station Factory Reset

To reset the system configuration to the factory defaults (erase the configuration) ensure that the master station is enabled, (please refer to section 6.3.1 Master Station Keyboard Enable). Then press and hold down the **ACCEPT**, **TALK**, **ALL** and **3** buttons simultaneously. The system status display will show **FACTORY RESET**. Continue holding these buttons until the system status display shows **SYSTEM RESET** the system configuration is now set to the factory defaults. Release the buttons and the system will perform an initial power up test, please refer to section 6.3.3 Master Station Initial Power up Test.

6.4 AUDIO LEVEL AND OTHER ADJUSTMENTS

The audio levels are factory set to a normal environment, if the factory set audio levels are unsuitable for the environment in which the system is installed then audio level adjustment may be required. The audio level for each outstation and the master station can be adjusted individually to suit the location in which they are installed.

Audio level adjust can only take place after the master station has been configured please refer to section 6.3 Master Station Configuration.

6.4.1 Master Station Audio Levels Adjustment

Once installed and powered up the master station tone level, (bleep level), speaker volume, and contrast should be adjusted should be adjusted to suit its location. The levels are adjusted using variable resistors located in the master station Please refer to section 11 Disabled Refuge EVC Components 11.5 to locate these variable resistors.

6.4.2 Outstations Audio Level Adjustment

Once installed and powered up the microphone and speaker volume for each outstation should be adjusted to suit its location. Compact system outstation audio levels are adjusted using variable resistors located in the master station. Standard System outstation levels are adjusted are adjusted using variable resistors located in the appropriate system controller.

Please refer to section 11.5 Compact System 5 Way Master Station (P/N RA7805.01), 11.6 Compact System 10 Way Master Station (P/N RA7810.01) or 11.11 Standard System Controller (P/N RA7700.02) to locate these variable resistors.

Visit each outstation in turn make a call to the master station and set the audio levels as required.

6.5 MASTER STATION AUDIO PATH TESTS CONFIGURATION

The system has an audio path test feature audible tones are sent to outstation speakers and detected by outstation microphones. The outgoing and incoming signals are compared testing the complete electrical and mechanical audio path between the outstation user and the control system.

Audio path tests are triggered by an internal timer. Configure the internal timer to trigger the audio path test as required. Please refer to the timer documentation. The internal timer will be found by the main system controller (standard system) or inside the master station (compact system) please see below.

If audio path testing is to be configured by a remote device configure the external audio path test trigger device, and connect to the input on the system master station (compact system) or input(s) on the system controller(s) (standard system).

If audio path testing is to be monitored by an external device configure the external device and connect to the master station fault output (compact system) audio path fault output(s) on the system controller(s) (standard system).

If possible cause the external system to trigger an audio path test and check that all systems respond correctly.

NOTE: The audio path tests require audible tones to be sent to each outstation in turn, therefore it is advisable to choose times to minimise possible disruption caused by outstation “noises”.

7 OPERATION

For the purposes of this manual we will refer to persons using the system from a refuge area as users, and persons operating the system from the master station as operators. For a diagram of your master station, please refer to section 11 Disabled Refuge EVC Components.

NOTE: this system should be operated in accordance to the relevant British Standards.

7.1 ENABLING THE MASTER STATION

The master station is fitted with a keyed enable switch to enable/disable the master panel buttons. This is used to prevent unauthorized persons operating the system and/or to enable the system in the event of emergency.

Before operating the system ensure that the system has been enabled by the appropriate persons according to local procedures i.e. turn the enable switch key clockwise. The system status panel will show **PANEL ENABLED**.

If required by local procedures disable the master station keyboard after use, i.e. turn the enable switch key anti-clockwise. The system status panel will show **SYSTEM NORMAL**.

7.2 ACCEPTING CALLS FROM OUTSTATIONS

When a user presses the call button on an outstation:-

- The outstation LED will flash.
- The master station sounder will sound (buzz).
- The button on the master station corresponding to the outstation will flash red.

The operator can accept the call by pressing the flashing button corresponding to the outstation, when accepted:-

- The LED on the corresponding outstation will be illuminated.
- The master station sounder will cease.
- The button on the master station corresponding to the outstation will be illuminated (not flashing).
- The operator will be able to hear the user.
- To talk to the user the operator must hold down the **TALK** button.
- Whilst the **TALK** button is pressed the operator will not be able to hear the user.

To cancel the call the operator presses the illuminated button corresponding to the user's outstation.

- The LED on the corresponding outstation will no longer be illuminated.
- The button on the master station corresponding to the outstation will no longer be illuminated.

NOTE: the Folknoll Disabled Refuge EVC system is a Push to Talk (PTT) system. The operator must hold down the TALK button to talk to the user.

7.3 MAKING CALLS TO OUTSTATIONS

To call an outstation the operator presses the button corresponding to the required outstation, once pressed:-

- The LED on the corresponding outstation will be illuminated.
- The button on the master station corresponding to the outstation will be illuminated (not flashing).
- The operator will now be able to hear the user.
- To talk to the user the operator must hold down the **TALK** button.

To cancel the call the operator presses the illuminated button corresponding to the user's outstation.

- The LED on the corresponding outstation will no longer be illuminated.
- The button on the master station button corresponding to the outstation will no longer be illuminated.

NOTE: the Folknoll Disabled Refuge EVC system is a Push to Talk (PTT) system. The operator must hold down the TALK button to talk to the user.

7.4 ALL CALLS

To talk to all of the outstations simultaneously (the operator cannot hear the outstations), for example to make a reassurance announcement the operator presses and holds down the **ALL** button. Once held down:-

- The LEDs on all of the outstations will be illuminated.
- The buttons on the master station corresponding to all of the connected outstations will be illuminated.
- The system status display will show **ALL CALL ACTIVE**
- The operator will be heard at all outstations.

To end the all call release the **ALL** button.

- The LEDs on all of the outstations will no longer be illuminated.
- The buttons corresponding to all of the connected outstations will no longer be illuminated.
- The system status display will briefly show **ALL CALL END** followed by **PANEL ENABLED**
- The operator will no longer be heard at any of the outstations.

NOTE: the Folknoll Disabled Refuge EVC system is a Push to Talk (PTT) system. The operator must hold down the ALL button to talk all of the outstations.

7.5 FIRE TELEPHONE OUTSTATIONS

Fire telephone outstations can be operated in hands-free or telephone-mode. The operating mode is selected by the outstation door. With the door closed the unit operates in hands free mode, with the door open the unit operates in telephone handset.

Master station operation, fault testing etc. is not affected by the outstation operating mode.

NOTE: In hands free mode operation is similar to a normal disabled refuge EVC outstation, operators and (passers-by) will hear the operators speech through the outstation speaker. In telephone mode operator audio will only be heard through the handset, it will not be possible to attract attention or make 'all call' announcements through the speaker.

7.6 FAULTS

The system automatically monitors and reports faults. Faults are usually indicated by the master station sounder and fault LED activating for 2 short bleeps and one long bleep continuously. An error message is usually shown on the system status display.

Usually the sounder can be silenced and the fault LED turned off by pressing the **ACCEPT** button, any fault message will remain on the system status display. Please refer to section 8 System Faults for further information.

The fault should be reported or repaired according to local procedures.

NOTE: Any temporary measures e.g. partial closures required by the nature of the fault, site conditions, local regulations and procedures should be put into effect immediately.

Please refer to section 8 System Faults.

7.7 MANUAL SYSTEM TEST (COMPACT SYSTEMS ONLY)

To initiate start a system test, press the **TEST** button on the compact system master station. The system will test each outstation intern and report any errors found.

NOTE: During testing outstations will generate audio tones. Testing should be timed to minimise inconvenience.

If an error is detected the sounder can be silenced and the fault LED turned off by pressing the **ACCEPT** button, any fault message will remain on the system status display. Please refer to section 8 System Faults for further information.

The fault should be reported or repaired according to local procedures.

NOTE: Any temporary measures e.g. partial closures required by the nature of the fault, site conditions, local regulations and procedures should be put into effect immediately.

7.8 TO DISABLE THE MASTER STATION KEYBOARD

If required by local procedures disable the master station keyboard after use, i.e. turn the enable switch key anti-clockwise. The system status panel will change from **PANEL ENABLED** to **SYSTEM NORMAL**.

8 SYSTEM FAULTS

The system automatically monitors and reports faults. Faults are usually indicated by the master station sounder and fault LED activating for 2 short bleeps and one long bleep continuously. An error message is usually shown on the system status display.

Usually the sounder can be silenced by pressing the **ACCEPT** button, fault message will remain on the system status display until the fault is resolved.

The fault should be reported / repaired according to local procedures.

NOTE: Any temporary measures e.g. partial closures required by the nature of the fault, site conditions, local regulations and procedures should be put into effect immediately.

8.1 SUMMARY OF SYSTEM FAULT INDICATIONS

SOUNDER	FAULT LED	DISPLAY	FAULT
Continuous 2 short bleeps followed by 1 long Bleep	Continuous 2 short flashes followed by 1 long Flash	PSU- FAULT	Power fail system running on PSU battery
Continuous 2 short bleeps followed by 1 long Bleep	Continuous 2 short flashes followed by 1 long Flash	Display is off.	Power fault and PSU battery "run out".
Silent	Fault LED is off	Display is off.	Power fault , PSU backup battery "run-out", master station configuration backup battery "run-out".
Continuous 2 short bleeps followed by 1 long Bleep	Continuous 2 short flashes followed by 1 long Flash	PLEASE ENABLE	System powered up with master station Keyboard disabled. Enable the master station keyboard please refer to 6.3.1 Master Station Keyboard Enable, proceed with power up procedure please refer to section 6.3.3 Master Station Initial Power up Test.
Continuous 2 short bleeps followed by 1 long Bleep	Continuous 2 short flashes followed by 1 long Flash	SUB XX AUD FAULT	Outstation XX has failed its audio test. There may be a cabling fault or an outstation fault. Report/repair the fault according to local procedures.
Master station 'buzzes' and an outstation button flashes.	No indication	No indication	A cable connecting the indicated (flashing button) outstation has occurred. Report/repair the fault according to local procedures.

Fig 8:1 Table of System Fault Messages

8.2 MAINS POWER FAIL

- The master station will continuously emit 2 short bleeps and one long bleep
- The master station fault LED will continuously give 2 short flashes and one long flash in time with the sounder.
- The system status display will show **PSU-FAULT**.
- The system will continue to operate from its standby power supply. If fully charged the system will remain on standby for at least 24 hours and allow 30 minutes of operation (calls announcements etc.).
- The sounder can be silenced and the fault LED turned off by pressing the **ACCEPT** button, any fault message will remain on the system status display.
- The mains supply should be restored as soon as possible

NOTE: If the power is not restored the standby batteries will 'run out' and the system will cease to be operational.

8.3 MAINS POWER AND PSU STANDBY BATTERY FAIL

- The master station will continuously emit 2 short bleeps and one long bleep
- The master station fault LED will continuously give 2 short flashes and one long flash in time with the sounder.
- The system status display will be off.
- System operation will not be possible.
- System configuration will be saved by the configuration battery.
- When power mains power is restored operation will resume and the system will automatically recharge the PSU standby batteries and configuration battery. The system will require a configuration test, please refer to section 6.3.4 Master Station Configuration Test.

8.4 CONFIGURATION BATTERY FAIL

- The master station sounder will no longer bleep and the fault LED will no longer flash.
- Normal operation will not be possible.
- The system configuration will be lost.
- When power mains power is restored operation will resume and the system will automatically recharge the PSU standby batteries and configuration battery. The system will require reconfiguration, please refer to section 6.3 Master Station Configuration

8.5 SYSTEM POWERED WITH MASTER STATION DISABLED

- The master station will continuously emit 2 short bleeps and one long bleep
- The master station fault LED will continuously give 2 short flashes and one long flash in time with the sounder.
- The system status display will show **PLEASE ENABLE**.
- To rectify the fault turn the keyed enabled switch and complete the power up procedure, please refer to section 6.3.3 Master Station Initial Power up Test.
- This situation should only occur during installation and maintenance.

NOTE: The system will not be operational until the power up procedure has been completed.

8.6 AUDIO PATH FAULT

Audio path tests are performed on initial power up and as triggered by the external timer or management system. If an outstation fails an audio path test:-

- The master station will continuously emit 2 short beeps and one long bleep
- The master station fault LED will continuously give 2 short flashes and one long flash in time with the sounder.
- The fault will be shown on the system status display. E.g. **SUB XX AUD FAULT**
- The sounder can be silenced and the fault LED turned off by pressing the **ACCEPT** button, any fault message will remain on the system status display.
- The fault should be reported / repaired immediately according to the local fault reporting procedure.

NOTE: The SUB or outstation indicated may not be operational until the fault is rectified.

8.7 OUTSTATION CABLE DISCONNECTED

- The master station will 'buzz' and the button on the master station corresponding to the outstation will flash.
- The 'buzz' can be silenced by accepting the call by pressing the button on the master station corresponding to the outstation.
- The fault should be reported / repaired according to the local fault reporting procedure.

NOTE: The SUB or outstation indicated will not be operational until the fault is rectified.

9 ROUTINE MAINTENANCE

This section gives a generic guide to the routine maintenance of Folknoll Disabled Refuge EVC systems. The maintenance procedure should be adapted to suit your system and its specific features.

Local maintenance, testing and repair procedures should be implemented according to local regulations, procedures, site conditions, risk assessment, and equipment installed.

Disabled refuge EVC systems are usually only used in the event of an emergency. Faults and other issues that develop may not be discovered until an emergency arises and the system is required. It is important that routine maintenance and frequent testing is carried out to ensure that the system is fully operational.

Folknoll Disabled Refuge EVC systems require minimal maintenance. The systems are robustly designed and have low wear as they are only used in emergency. The only parts to require regular maintenance are the PSU standby batteries.

9.1 STANDBY BATTERIES

The PSU standby batteries should be replaced as the battery manufacturer advises or at least every 3 years.

9.2 VISUAL INSPECTION

Disabled Refuge EVC systems are usually located in 'public' areas and depending on location can be open to abuse. The frequency of visual inspections should be determined by local regulations, procedures, site conditions, risk assessment and experience.

9.2.1 Outstations

System outstations should undergo frequent visual inspections to check:

- Outstations and signage are clearly visible and accessible by disabled persons, e.g. not hidden by posters, or behind a large object such as a roll cage, in a restricted area etc.
- Outstations show no signs of physical damage e.g. water ingress, impact.
- Outstations show no signs of other forms of abuse e.g. chewing gum in the microphone hole etc.
- Outstations show no signs of any other forms of damage that might affect visibility, access or operation.

9.2.2 Master Station

The master station should undergo frequent visual inspections to check:

- The master station and any signage are clearly visible and accessible by disabled persons, e.g. not hidden by posters, or behind a large object such as a roll cage, in a restricted area etc.
- The master stations show no signs of physical damage e.g. water ingress, impact.
- The master stations show no signs of other forms of abuse e.g. chewing gum in the microphone hole etc.
- The master stations show no signs of any other forms of damage that might affect visibility, access or operation.
- The master station enable key is present and accessible by all authorised operators.

9.2.3 Control Equipment (Standard System Only)

Any control equipment and exposed cable routes should undergo regular visual inspections to check:

- All control equipment and exposed cable routes show no signs of physical damage e.g. water ingress, impact.
- All control equipment and exposed cable routes show no signs of other forms of abuse
- All control equipment and exposed cable routes show no signs of any other forms of damage that might affect operation.

10 ROUTINE FUNCTIONAL TESTING

This section gives a generic guide to the routine functional testing of Folknoll Disabled Refuge EVC systems. The testing procedure should be adapted to suit the need of your system and its specific features.

Local maintenance, testing and repair procedures should be implemented according to local regulations, procedures, site conditions, risk assessment, and equipment installed.

Disabled refuge EVC systems are usually only used in the event of an emergency. Faults and other issues that develop may not be discovered until an emergency arises and the system is required. It is important that routine maintenance and frequent testing is carried out to ensure that the system is fully operational.

10.1 AUTOMATIC AUDIO PATH TESTING

The Folknoll disabled refuge EVC system has an automatic audio path testing feature. Audible tones are sent to outstation speakers and detected by outstation microphones. The outgoing and incoming signals are compared testing the complete electrical and mechanical audio path between the outstation user and the control system.

This feature should be triggered automatically by the disabled refuge control system internal timer please refer to section 1.2.9 Audio Path Fault Monitoring and Reporting. Audio faults should be detected automatically by the system and be reported / fixed according to local procedures.

The automatic audio path testing should be checked to ensure that is triggered regularly and responds correctly to faults please refer to section 10.8 Audio Path Tests Check (Microphone and Speaker Tests) and section 10.9 Automatic Audio Path Testing (Microphone and Speaker Tests).

10.2 USER CALL CHECK

For each outstation check the following:

- A call to the master station can be initiated by the outstation user.
- The master station responds correctly and the master station operator can accept the call.
- The outstation user can be clearly heard by the master station operator.
- The master station operator can be clearly heard by the outstation user.
- The call can be cancelled by the master station operator.

10.3 OPERATOR CALL CHECK

For each outstation check the following:

- A call to the outstation can be initiated by the master station user.
- The outstation user can be clearly heard by the master station operator.
- The master station operator can be clearly heard by the outstation user.
- The call can be cancelled by the master station operator.

10.4 ALL CALL CHECK

For each outstation check the following:

- An all call can be initiated by the master station user.
- The master station operator can be clearly heard by the outstation user.
- The all call can be cancelled by the master station operator.

10.5 STANDBY OPERATION TEST

Disconnect the mains supply and check the following:

- The master station reports power fail and the sounder can be silenced by pressing the master station **ACCEPT** button.
- Standard systems only check the PSU unit local alarm sounds and can be silenced, by pressing the PSU unit **SILENCE** button.
- The system is still operational (check that calls can be made).

Restore the mains supply and check the following:

- The master station no longer reports mains fail.
- The system is still operational (check that calls can be made).

10.6 STANDBY TIME TEST

If required by local regulations or procedures test the standby time by checking how the mains can be disconnected before the system fails.

The PSU should disconnect the batteries at 19V to prevent full discharge.

NOTE: this test should not be carried out on a live system because:

- The system will fail at some point.
- When the power is restored the standby time will be reduced.

Either of these conditions may violate site operation conditions and require closure of the site.

10.7 STANDBY BATTERY CHARGING VOLTAGE TEST

Access the PSU in the compact system master station or standard system PSU. Disconnect the batteries (BAT – and BAT +) terminals. Check voltage across the load outputs (0V and 27V3). is $27.3 \pm 0.2V$ d.c. @20°C. No adjustment possible.

10.8 AUDIO PATH TESTS CHECK (MICROPHONE AND SPEAKER TESTS)

To verify that the system responds correctly in the event of an audio path test failure, cause a failure by covering an outstation microphone or disconnecting an outstation speaker circuit.

Trigger an audio path test by pressing the test button on the master station (compact system) or shorting the input(s) on system controller(s) (standard system). Check the system reports audio path failure for the correct outstation(s), please refer to section 8 System Faults.

Check that appropriate audio fault outputs are also triggered and any monitoring devices e.g. the BMS respond correctly.

Rectify the faults caused and trigger an audio path test, check that no faults are detected.

10.9 AUTOMATIC AUDIO PATH TESTING (MICROPHONE AND SPEAKER TESTS)

Check that the automatic audio path testing is triggered by the internal timer at the times configured, i.e. either observe the test or maintain and inspect records.

Check that any fitted external timers or management systems trigger audio path tests as configured.

11 DISABLED REFUGE EVC COMPONENTS

11.1 EXTERNAL OUTSTATION (P/N RA7700.60)



Fig 11:1 External Outstation

11.1.1 Features

- Weather resistant IP65 enclosure designed for external use
- Bright yellow die cast aluminium fascia
- Mild Steel black painted back box
- Integral speaker and microphone, high audio output (80 dB)
- Large call button, progress LED
- Can be used with compact or standard systems

11.1.2 Description

The single button external outstation is a vandal resistant IP65 bright yellow and black die cast aluminium outstation designed for external use.

The unit has an integral microphone and speaker and is fitted with large vandal resistant call button and a call progress.

The speaker and microphone volume are adjustable to suite the operating environment with a maximum output of 80 dB for noisy areas.

The unit is usually mounted in the refuge area and is used by refugees to communicate with the system operator in the event of an emergency.

This unit is annotated in black with the words **REFUGE ALARM** and **PRESS ONCE TO CALL**; alternative annotation is available on request.

The unit is supplied with a surface mount back box.

11.2 INTERNAL OUTSTATION (P/N RA7700.30 AND RA7700.35)

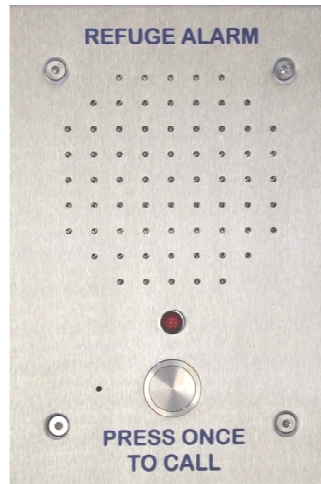

Fig 11:3 Vandal Resistant Outstation

11.2.1 Features

- Vandal resistant design
- Stainless steel fascia
- Mild steel back box
- Surface or flush mount
- Integral speaker and microphone, high audio output (80 dB)
- Vandal resistant call button, progress LED
- Can be used with compact or standard systems

11.2.2 Description

The internal outstation is a vandal resistant outstation with stainless steel fascia and mild steel painted back box.

The unit has an integral microphone and speaker and is fitted with large vandal resistant call button and a call progress LED.

The speaker and microphone volume are adjustable to suite the operating environment with a maximum output of 80 dB for noisy areas.

The unit is usually mounted in the refuge area and is used by refugees to communicate with the system operator in the event of an emergency.

This unit is annotated in blue with the words **REFUGE ALARM** and **PRESS ONCE TO CALL**; alternative annotation is available on request.

The unit can be supplied with surface or flush mount back box.

This unit is suitable for use with compact and standard Folknoll Disabled Refuge EVC systems.

11.2.3 Part Numbers

RA7700.30
RA7700.35

Surface mount, stainless steel, vandal resistant outstation
Flush mount, stainless steel, vandal resistant outstation

11.2.4 Specifications

Fascia:	Stainless steel, brushed finish, black annotation
Surface back box:	Mild steel, black painted
Flush back box:	Mild steel
Dimensions:	Width:130mm, Height:190mm, (approx.)
Power:	Line powered
Audio output:	Max:80 dB

11.2.5 Connections

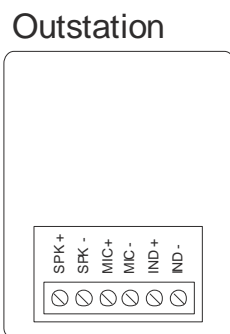

Fig 11:4 Outstation Connections

11.3 PRO OUTSTATION (P/N RA7700.40 AND RA7700.45)

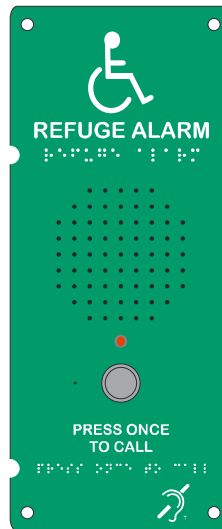

Fig 11:5 Pro Outstation

11.3.1 Features

- Green photo luminescent fascia
- Braille and photo luminescent annotation
- Integral induction loop
- Adjustable audio output (up to 80 dB)
- Suitable for standard and compact EVC systems
- Vandal resistant
- Large call button
- Call progress LED
- Integral speaker microphone
- Line powered
- Anti-tamper fixings
- Surface or flush mount

11.3.2 Description

The single button pro outstation is a photo luminescent green vandal resistant outstation with integral induction loop and braille annotation.

The unit has an integral microphone and speaker and is fitted with large vandal resistant call button and a call progress LED. The speaker and microphone volume are adjustable to suite the operating environment with a maximum audio output of 80 dB for noisy areas.

The vandal resistant enclosure has a steel backed fascia and a mild steel back box with anti-tamper fixings and a surface or flush mount back box. The fascia is supplied as standard with white photo luminescent and braille annotation alternative annotation is available on request.

This unit is suitable for use with compact and standard Folknoll Disabled Refuge EVC systems.

11.3.3 Part Numbers

RA7700.40
RA7700.45

Surface mount pro disabled refuge EVC outstation
Flush mount pro disabled refuge EVC outstation

11.3.4 Specifications

Fascia:	Steel backed photo luminescent green fascia with braille and white annotation.
Mounting (surface):	Surface mount black painted mild steel back box (supplied).
Mounting (flush):	Or flush mount mild steel back box (supplied).
Dimensions:	Width: 127 mm, height: TBA mm (approx.)
Power:	Line powered
Audio output:	Adjustable up to 80 dB
Induction loop:	Fitted

11.3.5 Connections

Outstation

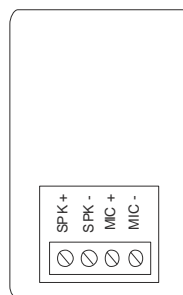

Fig 11:6 Pro Outstation Connections

11.4 FIRE TELEPHONE OUTSTATION (P/N RA7700.50 AND RA7700.55)



Fig 11:7 Fire Telephone Outstation

11.4.1 Features

- Bright red BS5839:9 compliant fire telephone
- Integral speaker for hands-free operation
- Adjustable audio output (up to 80 dB)
- Internal handset (activated by opening the door) for telephone operation
- Suitable for standard and compact EVC systems
- Internal call button
- Internal progress LED
- Integral speaker microphone
- Line powered
- High quality vandal resistant steel case
- Anti-tamper fixings
- Surface or flush mount

11.4.2 Description

Fire telephone outstation(s) can be added to a compact or standard disabled refuge EVC system to provide a BS5839:9 compliant combined refuge/fire telephone/toilets. Saving control room space, equipment room space cabling etc.

The unit has an integral speaker for hands free operation and an internal handset set for telephone operation. The unit automatically switches from hands free to telephone operation when the door is opened.

The unit can be called from the master station allowing the operator to attract the attention of users or to make 'all call' announcements.

A call button and a call progress LED is located inside the unit to enable the outstation user to call the master station.

The speaker and microphone volume are adjustable to suite the operating environment with a maximum audio output of 80 dB for noisy areas.

The vandal resistant enclosure has a steel fascia and a mild steel back box with anti-tamper fixings and a surface or flush mount back box. The fascia is supplied as standard with white 'fire telephone' annotation alternative annotation is available on request.

This unit is suitable for use with compact and standard Folknoll Disabled Refuge EVC systems.

11.4.3 Part Numbers

RA7700.50	Surface mount fire telephone disabled refuge EVC outstation
RA7700.55	Flush mount fire telephone disabled refuge EVC outstation

11.4.4 Specifications

Fascia:	Vandal resistant red painted steel fascia with fire telephone annotation in white.
Mounting (surface):	Surface mount red painted mild steel back box (supplied).
Mounting (flush):	Or flush mount mild steel back box (supplied).
Dimensions:	Width: TBA mm, height: TBA mm (approx.)
Power:	Line powered
Speaker audio output:	Adjustable up to 80 dB
Induction loop:	Fitted

11.4.5 Connections

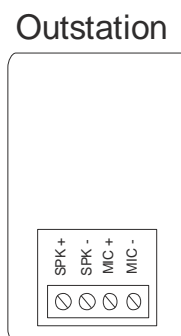

Fig 11:8 Fire Telephone Outstation Connections

11.5 COMPACT SYSTEM 5 WAY MASTER STATION (P/N RA7805.01)



Fig 11:9 Compact System Five Way Master Station

11.5.1 Features

- Controls up to 5-off outstations
- Keyed enable switch
- LCD system status display
- Fault LED
- Internal speaker ,internal microphone
- High audio output for noisy environments (80 dB)
- Audio path fault monitoring and reporting, internal and external triggers
- Mains supply monitoring and reporting
- I/O for BMS or other external systems
- Matches standard fire panel size and quality
- Customisable area label
- Surface semi flush mount
- Security screws

11.5.2 Description

The compact system 5 way master station is a surface/flush wall mounted master station for Disabled Refuge EVC systems of up to 5-off outstations.

All compact system master stations are designed to match standard fire panel size and quality.

The unit has an integral microphone, speaker, system controller, PSU and standby batteries. The unit is fitted with an LCD display, keyed enable switch, fault LED and large control buttons.

The speaker and microphone volume are adjustable to suite the operating environment with a maximum output of 80 dB for noisy areas.

The unit is usually mounted in the control area and is used by the system operator to communicate with the system users in the event of an emergency.

This unit is annotated in black, alternative annotation is available on request.

A refuge area label is provided for noting meaningful refuge area names. The refuge area label and a simplified operating instruction label are mounted on the front panel of the master station to aid operators. A copy of the refuge area label may be found in section 13 APPENDIX B Compact System Master Station Labels.

11.5.3 Part Numbers

RA7805.01	5 way surface mount compact system master station
RA7850.00	Bezel for semi flush mount
RA7750.00	Battery set

11.5.4 Specifications

Fascia:	Stainless steel, brushed finish, black annotation
Enclosure:	Mild steel, grey painted
Mounting:	Surface
Dimensions (surface mount):	Width:450mm, Height:325mm, Depth:125mm (approx.)
Dimensions (semi flush mount):	Width:450mm, Height:325mm, Depth:100+25mm (approx.)
Power:	230 Vac
Audio path test input:	Volt free
Remote enable input	Volt free
System fault output:	Closing contact (COM/NC/NO)
Audio output:	Max: 80 dB

11.5.5 Connections

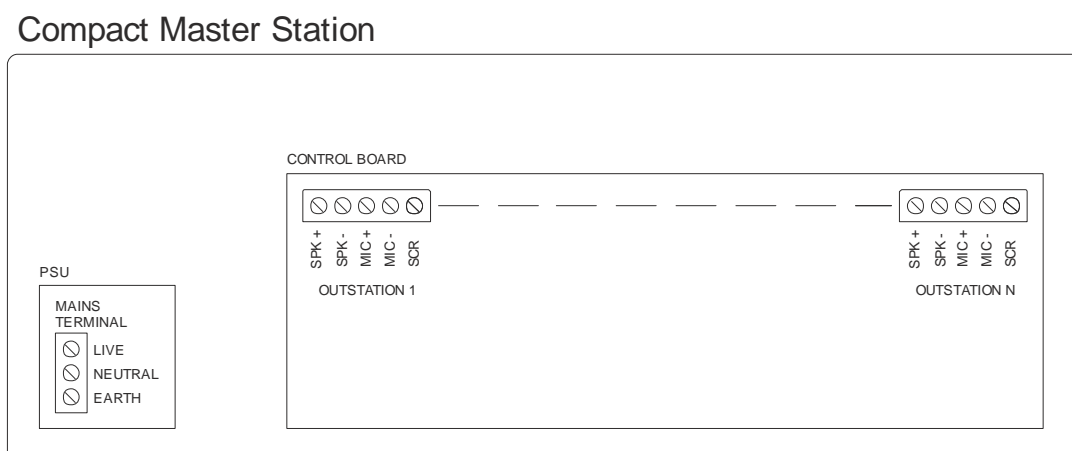

Fig 11:10 Compact Master Station Connections

11.5.6 Master Station Levels Adjustment

Master station tone (bleep) level volume (speaker) level microphone gain and contract are adjusted using variable resistors located on the rear of the master station door. Please refer to the picture below:-



Fig 11:11 Rear Panel of Compact Master Station Door

11.5.7 Outstation Levels Adjustment

Outstation speaker and microphone levels re are adjusted using variable resistors located on the master station main PCB which is located on the master station backboard please refer to the diagram below:-

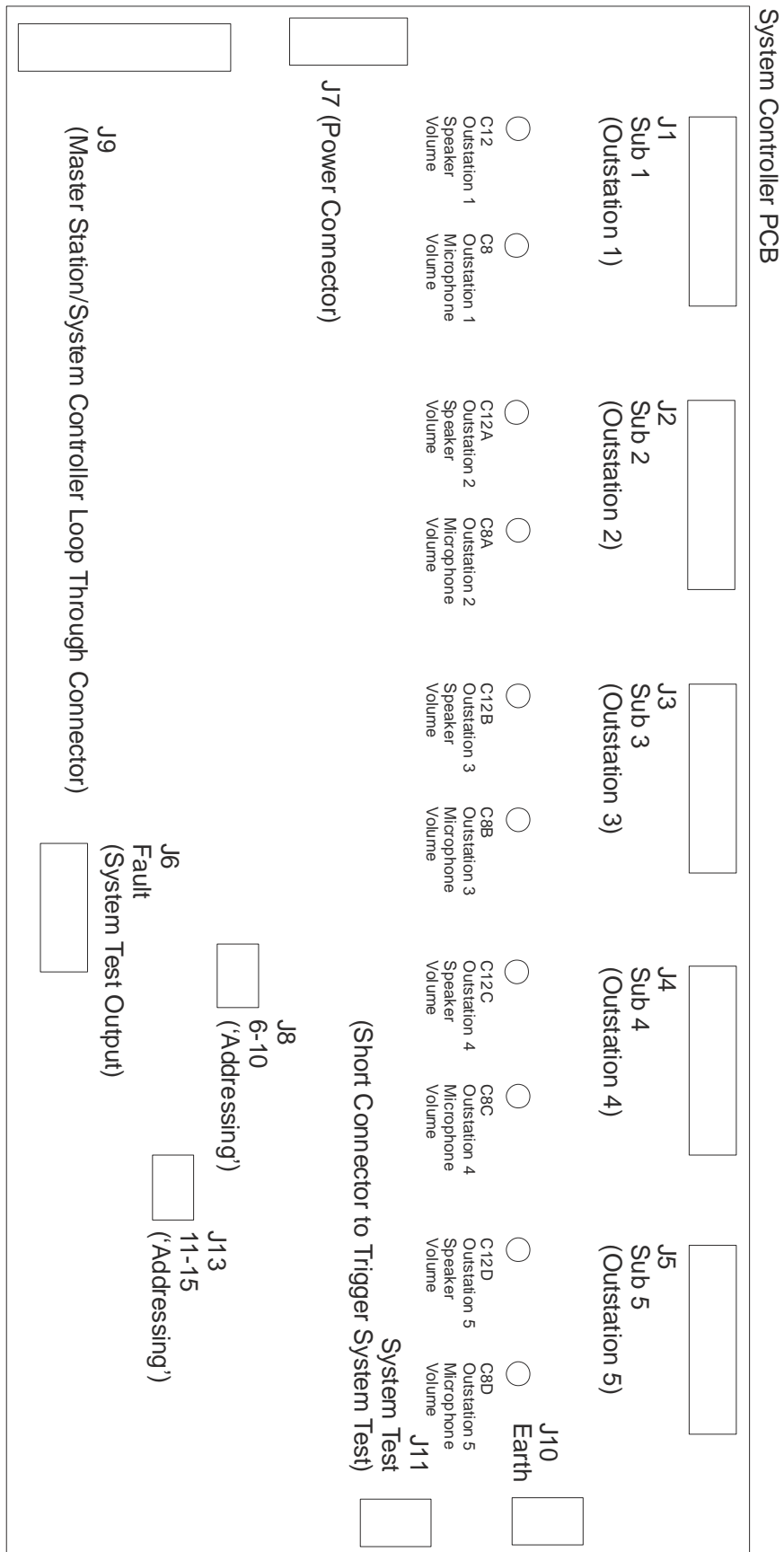

Fig 11:12 Compact Master Station Main PCB Layout

11.6 COMPACT SYSTEM 10 WAY MASTER STATION (P/N RA7810.01)

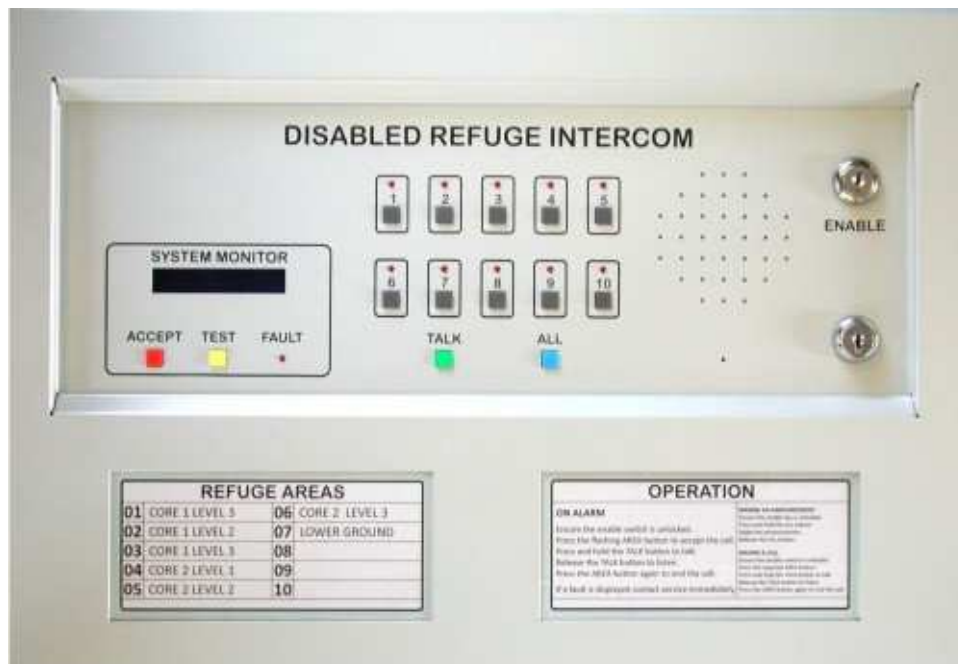

Fig 11:13 Compact System Ten Way Master Station

11.6.1 Features

- Controls up to 10-off outstations
- Keyed enable switch
- LCD system status display
- Fault LED
- Internal speaker ,internal microphone
- High audio output for noisy environments (80 dB)
- Audio path fault monitoring and reporting, internal and external triggers
- Mains supply monitoring and reporting
- I/O for BMS or other external systems
- Matches standard fire panel size and quality
- Customisable area label
- Surface or semi flush mount
- Security screws

11.6.2 Description

The compact system 10 way master station is a surface/flush wall mounted master station for Disabled Refuge EVC systems of up to 10 outstations.

All compact system master stations are designed to match standard fire panel size and quality.

The unit has an integral microphone, speaker, system controller, PSU and standby batteries. The unit is fitted with an LCD display, keyed enable switch, fault LED and large control buttons.

The speaker and microphone volume are adjustable to suite the operating environment with a maximum output of 80 dB for noisy areas.

The unit is usually mounted in the control area and is used by the system operator to communicate with the system users in the event of an emergency.

This unit is annotated in black, alternative annotation is available on request.

A refuge area label is provided for noting meaningful refuge area names. The refuge area label and a simplified operating instruction label are mounted on the front panel of the master station to aid operators. A copy of the refuge area label may be found in section 13 APPENDIX B Compact System Master Station Labels.

11.6.3 Part Numbers

RA7810.01	10 way surface mount compact system master station
RA7850.00	Bezel for semi flush mount
RA7750.00	Battery set

11.6.4 Specifications

Fascia:	Stainless steel; brushed finish; black annotation.
Enclosure:	Mild steel; grey painted
Mounting:	Surface
Dimensions (surface mount):	Width:450mm, Height:325mm, Depth:125mm (approx.)
Dimensions (semi flush mount):	Width:450mm, Height:325mm, Depth:100+25mm (approx.)
Power:	230 Vac
Audio path test input:	Volt free
Remote enable input:	Volt free
System fault output:	Closing contact (COM/NC/NO)
Audio output:	Max: 80 dB

11.6.5 Connections

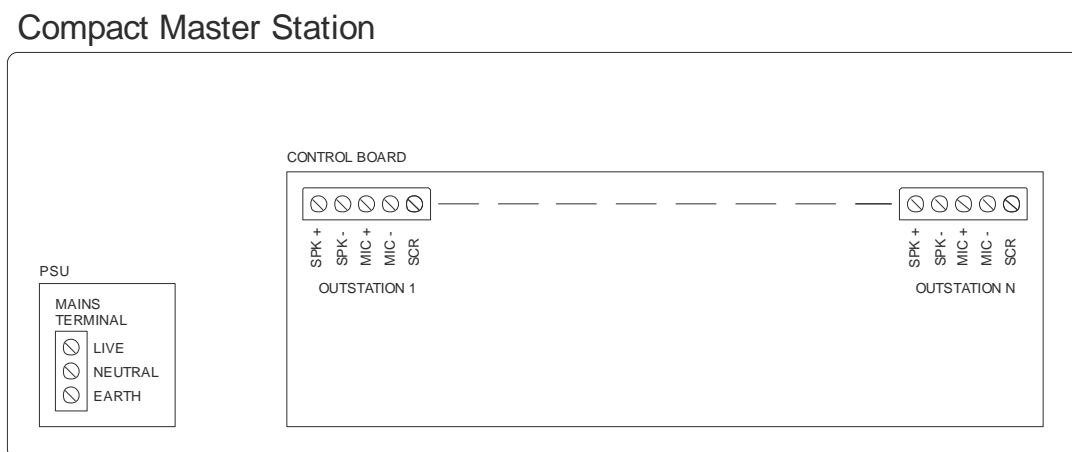

Fig 11:14 Compact Master Station Connections

11.6.6 Master Station Levels Adjustment

Master station tone (bleep) level volume (speaker) level microphone gain and contract are adjusted using variable resistors located on the rear of the master station door. Please refer to the picture below:-



Fig 11:15 Rear Panel of Compact Master Station Door

11.6.7 Outstation Levels Adjustment

Outstation speaker and microphone levels re are adjusted using variable resistors located on the master station main PCB which is located on the master station backboard please refer to the diagram below:-

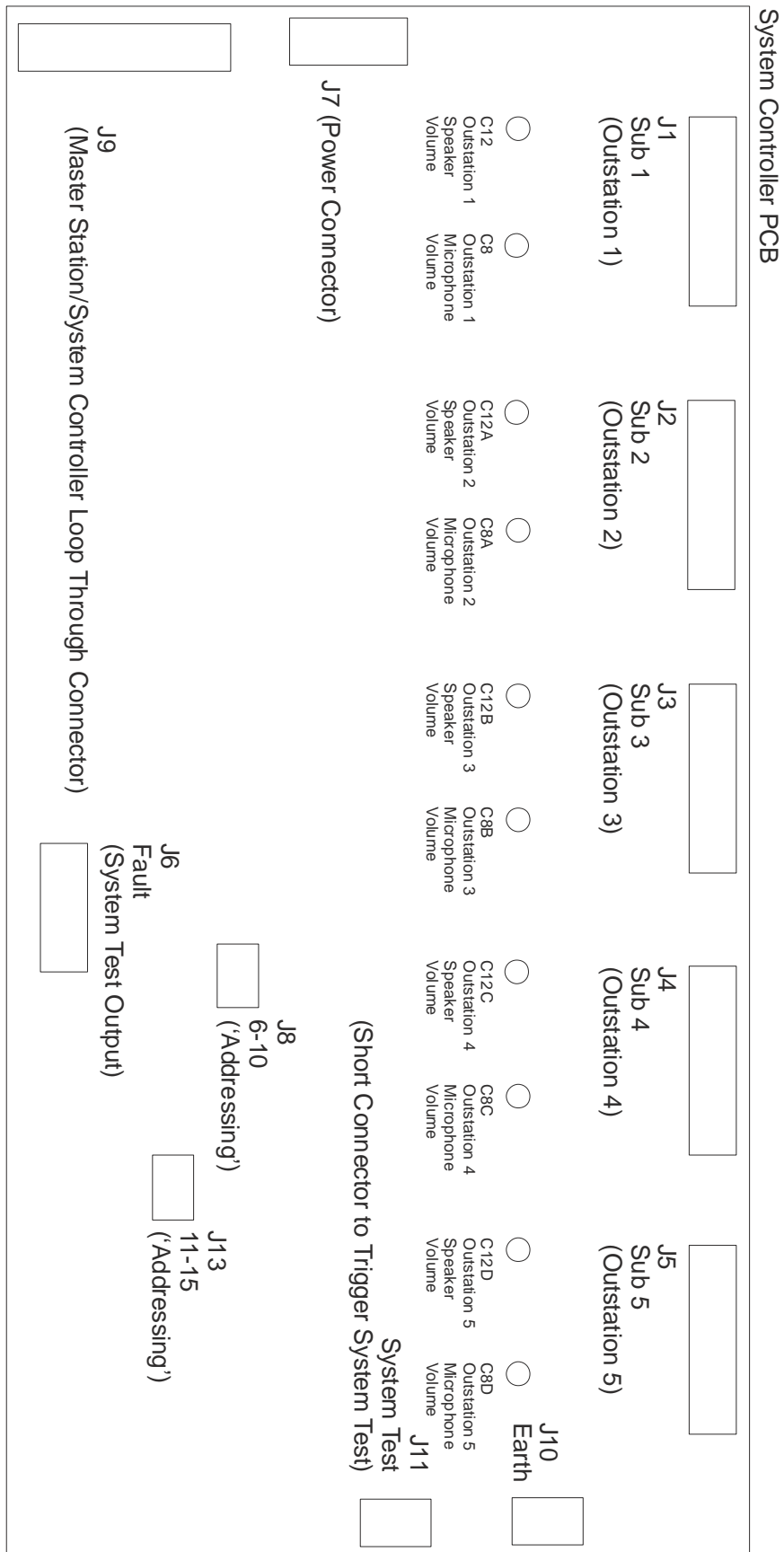

Fig 11:16 Compact Master Station Main PCB Layout

11.7 STANDARD SYSTEM 5 WAY MASTER STATION (P/N RA7705.01 RA7705.05)



Fig 11:17 Standard System Five Way Master Station

11.7.1 Features

- Controls up to 5-off outstations
- Keyed enable switch
- Optional custom outstation labels
- LCD system status display
- Fault LED
- Internal speaker ,internal microphone
- High audio output for noisy environments (80 dB)
- Surface or flush mount
- Vandal resistant design
- Security screws

11.7.2 Description

The 5-way standard system master station is a surface/flush desk/wall mounted master station with stainless steel fascia and painted mild steel back boxes for systems of up to 5 outstations.

The unit has an integral microphone and speaker and is fitted and LCD display, keyed enable switch, fault LED and large control button.

The speaker and microphone volume are adjustable to suite the operating environment with a maximum output of 80 dB for noisy areas.

The unit is usually mounted in the control area and is used by operator to communicate with the system users in the event of an emergency.

This unit is annotated in black, alternative annotation is available on request.

The unit can be supplied with surface or flush mount back box.

11.7.3 Part Numbers

RA7705.01	Surface mount, stainless steel, vandal resistant, 5 way standard system master station
RA7705.05	Flush mount, stainless steel, vandal resistant, 5 way standard system master station

11.7.4 Specifications

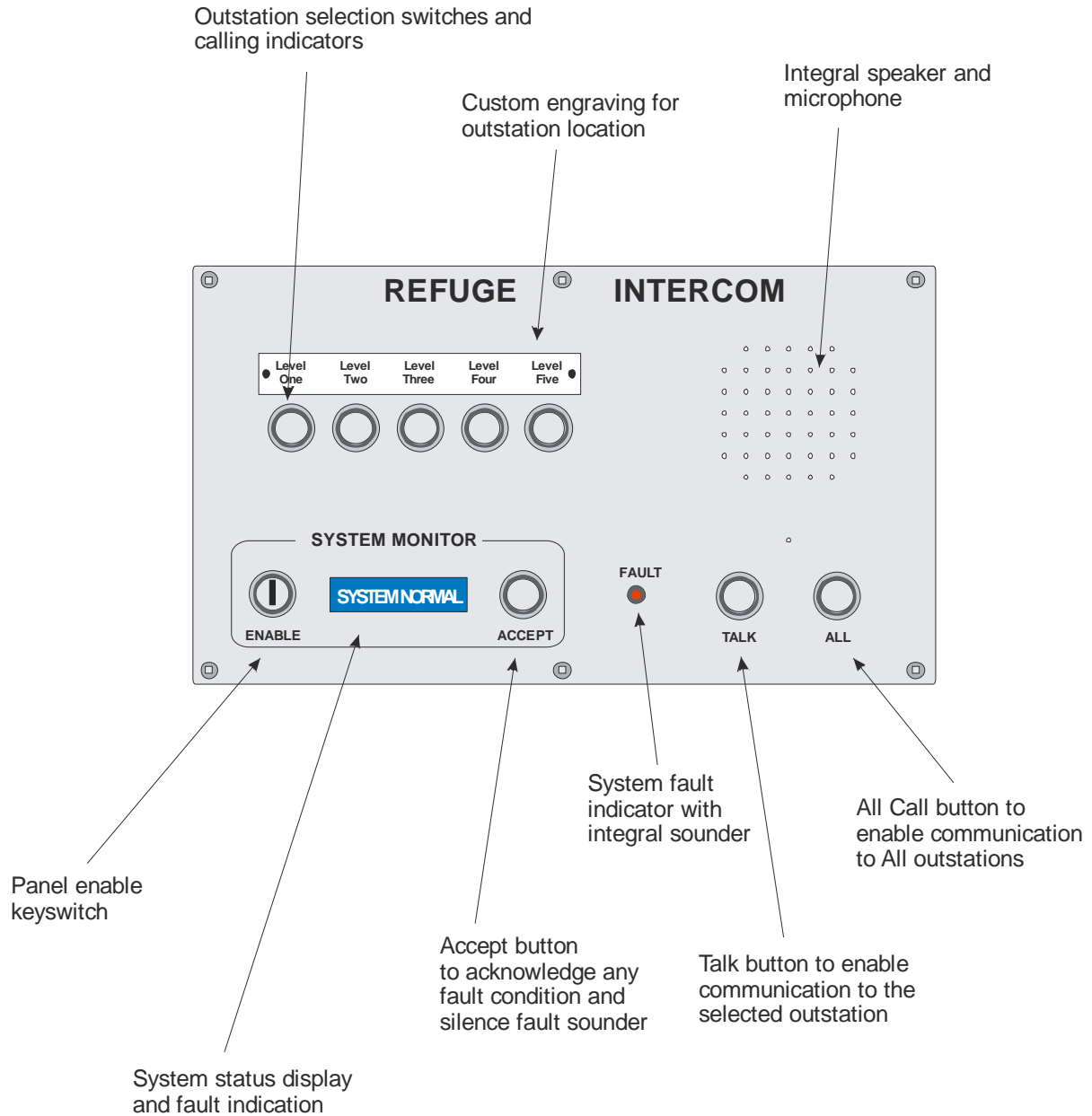
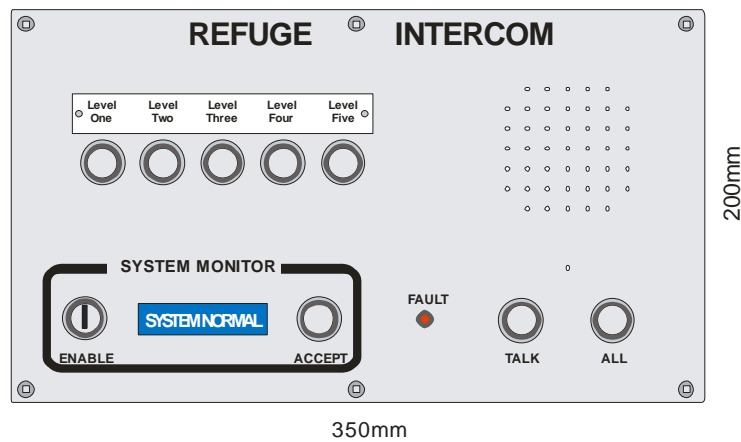
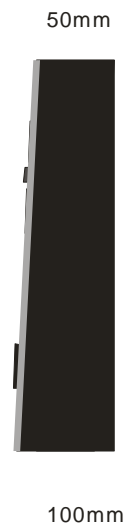

Fig 11:18 Standard System Five Way Master Station Features

Panel



Surface Mount



Flush Fitting Bezzel

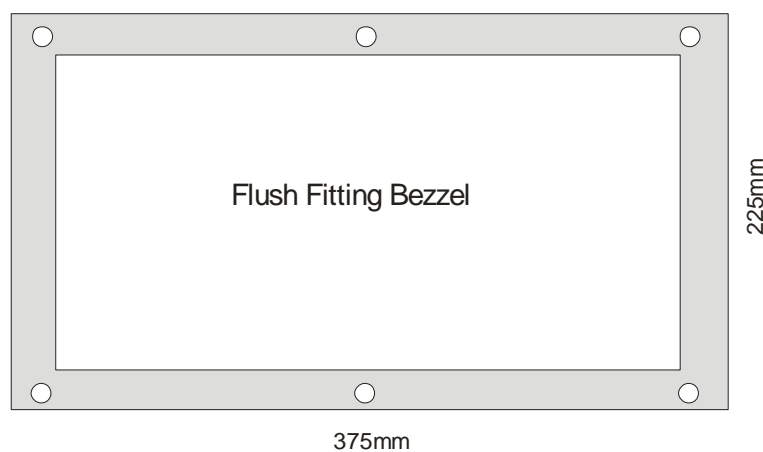

Flush Mount



Fig 11:19 Standard System Five Way Master Station Dimensions

Fascia:	Stainless steel, brushed finished, black annotation
Surface back box:	Mild steel, black painted
Flush back box:	Mild steel
Dimensions (surface mount):	Width:350mm, Height:200mm, Depth:50-100mm (approx.)
Dimensions (flush mount):	Width:350mm, Height:200mm, Depth:55mm (approx.)
Power:	24V from standard system monitored battery backed PSU
Audio output:	Max: 80 dB

11.7.5 Connections

Standard Master Station

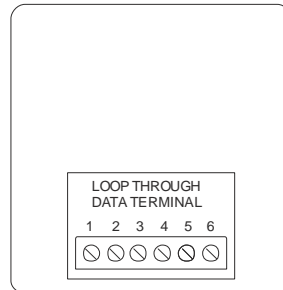

Fig 11:20 Standard Master Station Connections

11.8 STANDARD SYSTEM 10 WAY MASTER STATION (P/N RA7710.01 RA7710.05)



Fig 11:21 Standard System Ten Way Master Station

11.8.1 Features

- Controls up to 10-off outstations
- Keyed enable switch
- Optional custom outstation labels
- LCD system status display
- Fault LED
- Internal speaker ,internal microphone
- High audio output for noisy environments (80 dB)
- Surface or flush mount
- Vandal resistant design
- Security screws

11.8.2 Description

The 10 way standard system master station a surface/flush desk/wall mounted master station with stainless steel fascia and painted mild steel back boxes for systems of up to 10 outstations.

The unit has an integral microphone and speaker and is fitted and LCD display, keyed enable switch, fault LED and large control button.

The speaker and microphone volume are adjustable to suite the operating environment with a maximum output of 80 dB for noisy areas.

The unit is usually mounted in the control area and is used by operator to communicate with the system users in the event of an emergency.

This unit is annotated in black, alternative annotation is available on request.

The unit can be supplied with surface or flush mount back box.

11.8.3 Part Numbers

RA7710.01	Surface mount, stainless steel, vandal resistant, 10 way standard system master station
RA7710.05	Flush mount, stainless steel, vandal resistant, 10 way standard system master station

11.8.4 Specifications

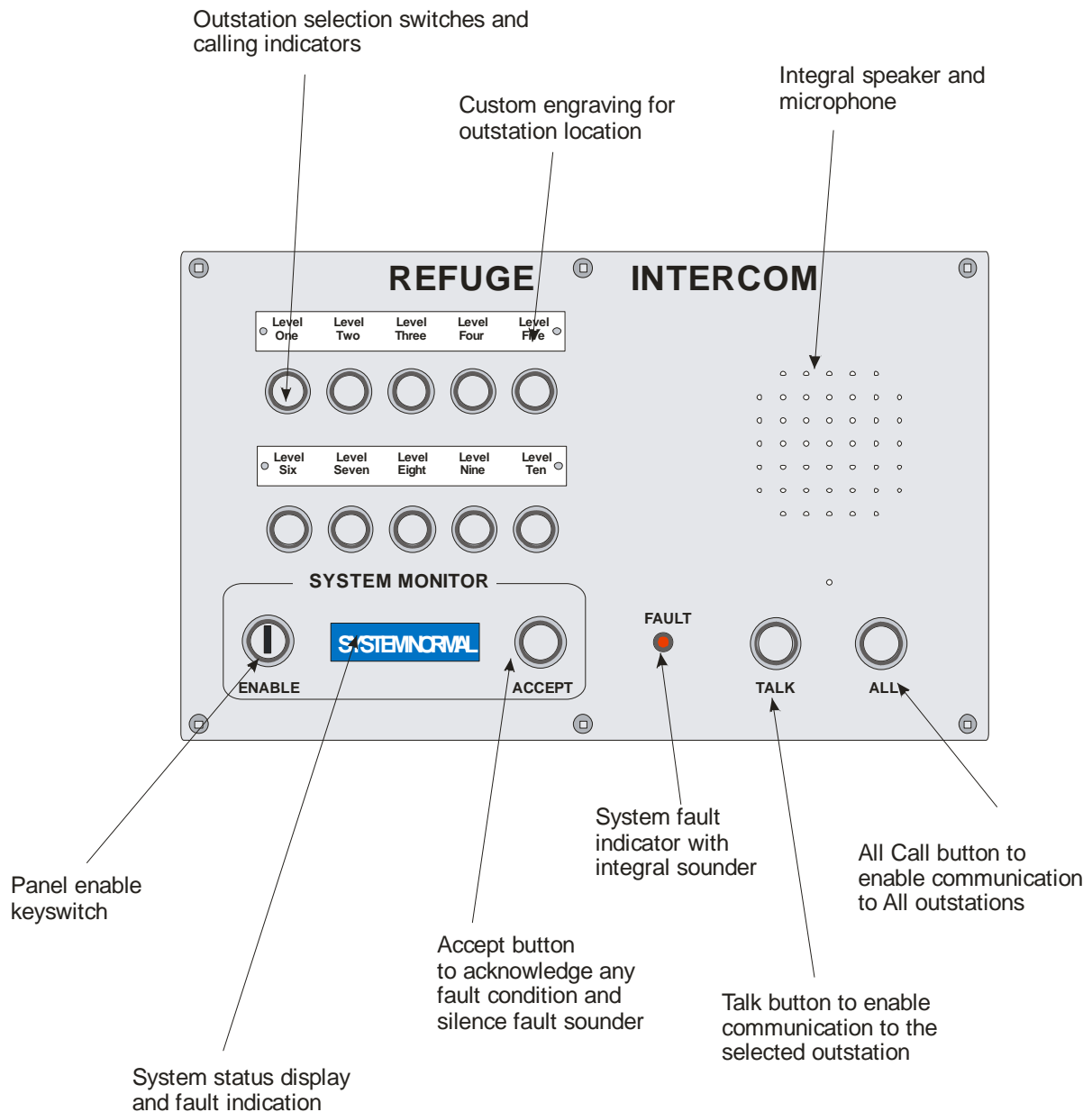
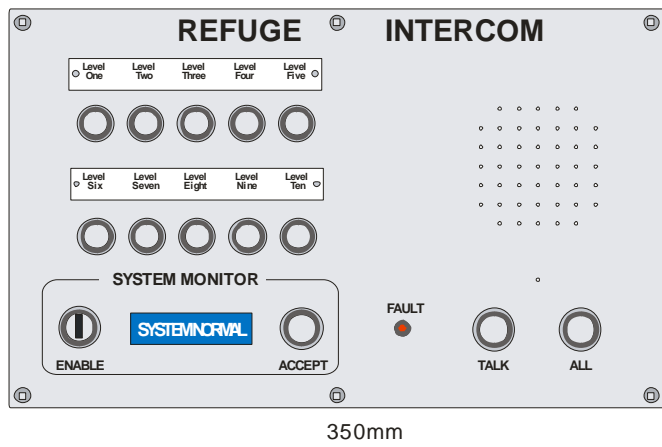
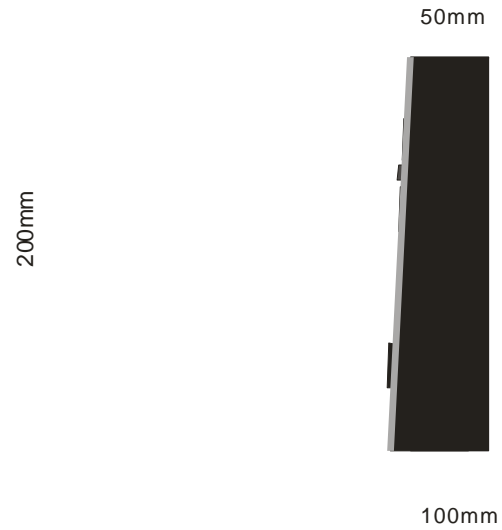

Fig 11:22 Standard System Ten Way Master Station Features

Panel



Surface Mount



Flush Fitting Bezzel

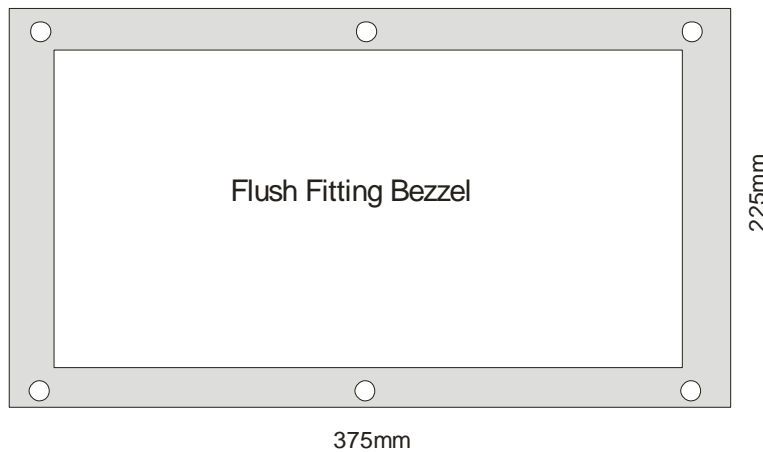

Flush Mount

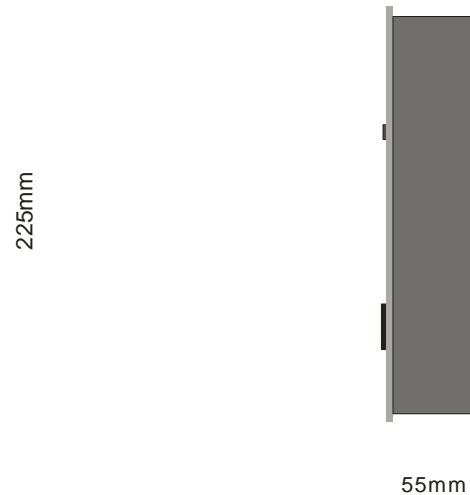

Fig 11:23 Standard System Ten Way Master Station Dimensions

Fascia:	Stainless steel, brushed finished, black annotation
Surface back box:	Mild steel, black painted
Flush back box:	Mild steel
Dimensions (surface mount):	Width 350mm, Height 200mm, Depth 50-100mm (approx.)
Dimensions (flush mount):	Width:350mm, Height:200mm, Depth:55mm (approx.)
Power:	24V from standard system monitored battery backed PSU
Audio output:	Max: 80 dB

11.8.5 Connections

Standard Master Station

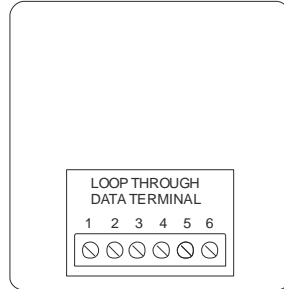

Fig 11:24 Standard Master Station Connections

11.9 STANDARD SYSTEM 15-WAY MASTER STATION (P/N RA7715.01 RA7715.05)



Fig 11:25 Standard System Fifteen Way Master Station

11.9.1 Features

- Controls up to 15-off outstations
- Keyed enable switch
- Optional custom outstation labels
- LCD system status display
- Fault LED
- Internal speaker ,internal microphone
- High audio output for noisy environments (80 dB)
- Surface or flush mount
- Vandal resistant design
- Security screws

11.9.2 Description

The 15 way standard system master station is a surface/flush desk/wall mounted master station with stainless steel fascia and painted mild steel back boxes for systems of up to 15 outstations.

The unit has an integral microphone and speaker and is fitted and LCD display, keyed enable switch, fault LED and large control button.

The speaker and microphone volume are adjustable to suite the operating environment with a maximum output of 80 dB for noisy areas.

The unit is usually mounted in the control area and is used by operator to communicate with the system users in the event of an emergency.

This unit is annotated in black, alternative annotation is available on request.

The unit is supplied with a flush mount back box which can fitted into a black painted wood surround for use on a console.

11.9.3 Part Numbers

RA7715.01	Surface mount, stainless steel, vandal resistant,15 way standard system master station
RA7715.05	Flush mount, stainless steel, vandal resistant, 15 way standard system master station

11.9.4 Specifications

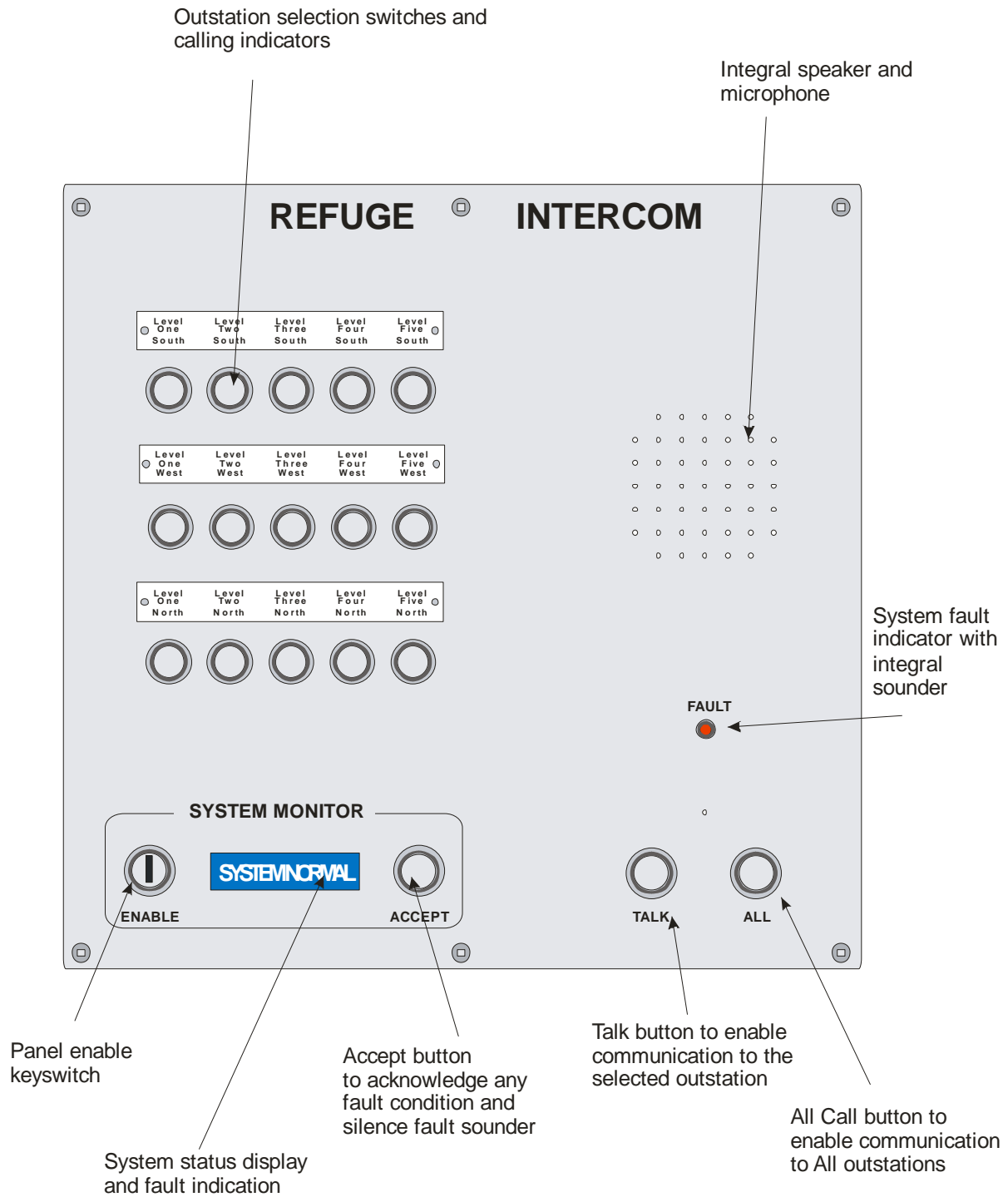
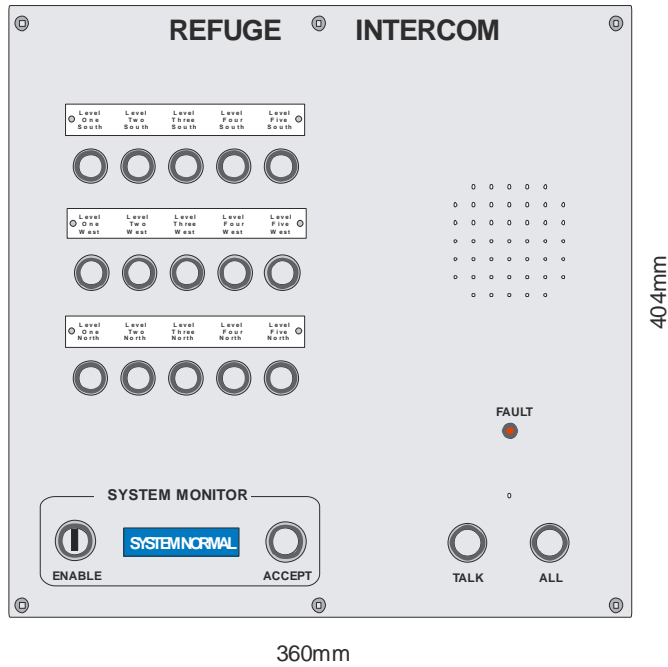
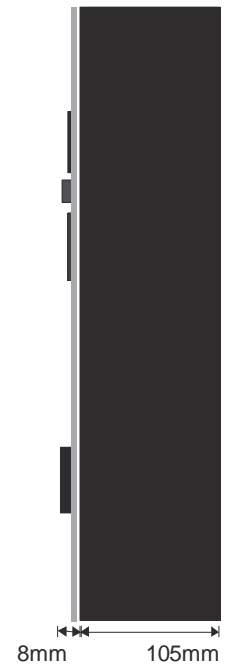

Fig 11:26 Standard System Fifteen Way Master Station Features

Panel



Console Mount



Flush Fitting Bezel

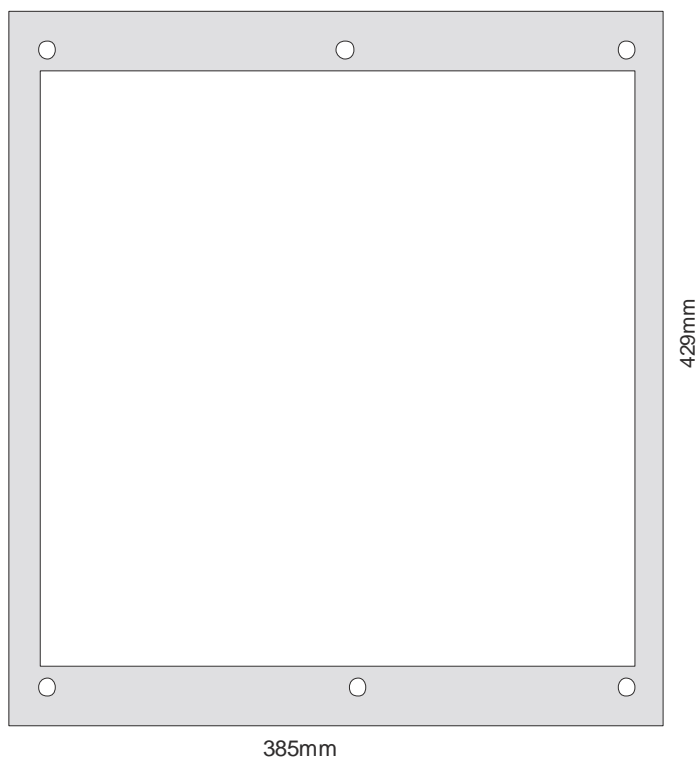

Flush Mount

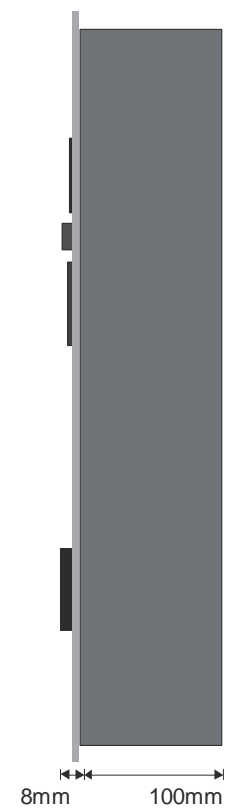

Fig 11:27 Standard System Fifteen Way Master Station Dimensions

Fascia:	Stainless steel, brushed finished, black annotation
Console mount:	Wood surround, black painted, mild steel flush back box insert.
Flush back box:	Mild steel.
Dimensions (console mount):	Width 360mm, Height 404mm, Depth 113mm (approx.)
Dimensions (flush mount):	Width 360mm, Height 404mm, Depth 108mm (approx.)
Power:	24V from standard system monitored battery backed PSU
Audio output:	Max: 80 dB

11.9.5 Connections

Standard Master Station

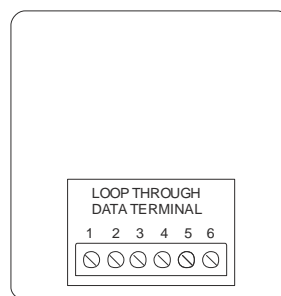

Fig 11:28 Standard Master Station Connections

11.10 STANDARD SYSTEM 20-WAY MASTER STATION (P/N RA7720.01 RA7720.05)

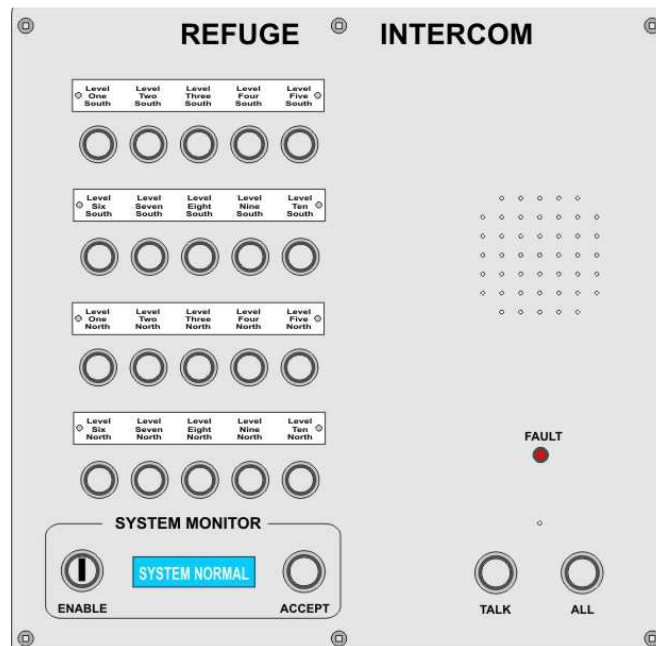

Fig 11:29 Standard System Twenty Way Master Station

11.10.1 Features

- Controls up to 20-off outstations
- Keyed enable switch
- Optional custom outstation labels
- LCD system status display
- Fault LED
- Internal speaker ,internal microphone
- High audio output for noisy environments (80 dB)
- Surface or flush mount
- Vandal resistant design
- Security screws

11.10.2 Description

The 20 way standard system master station is a surface/flush desk/wall mounted master station with stainless steel fascia and painted mild steel back boxes for systems of up to 20 outstations.

The unit has an integral microphone and speaker and is fitted and LCD display, keyed enable switch, fault LED and large control button.

The speaker and microphone volume are adjustable to suite the operating environment with a maximum output of 80 dB for noisy areas.

The unit is usually mounted in the control area and is used by operator to communicate with the system users in the event of an emergency.

This unit is annotated in black, alternative annotation is available on request.

The unit is supplied with a flush mount back box which can fitted into a black painted wood surround for use on a console.

11.10.3 Part Numbers

RA7720.01	Surface mount, stainless steel, vandal resistant,20 way standard system master station
RA7720.05	Flush mount, stainless steel, vandal resistant,20 way standard system master station

11.10.4 Specifications

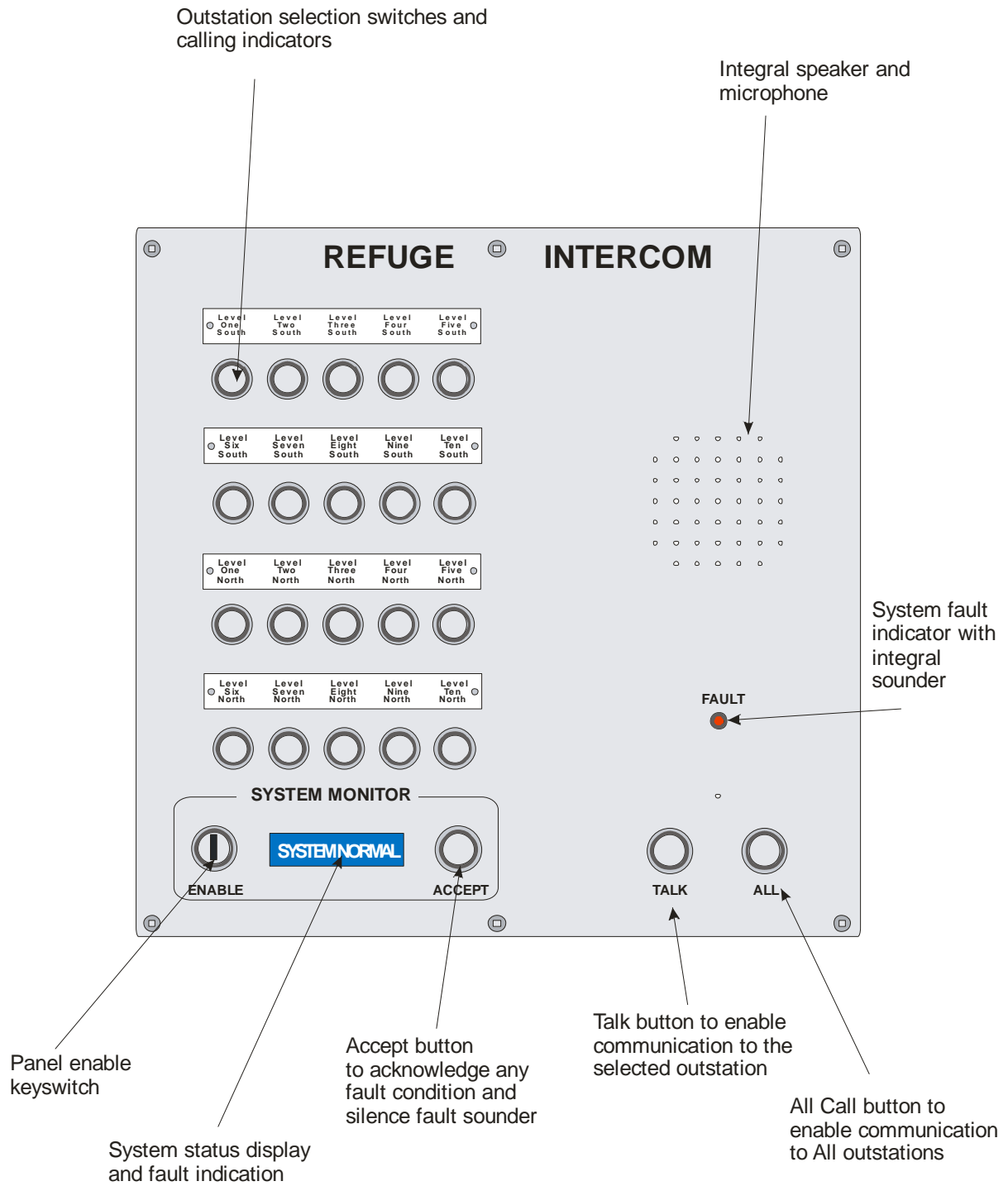
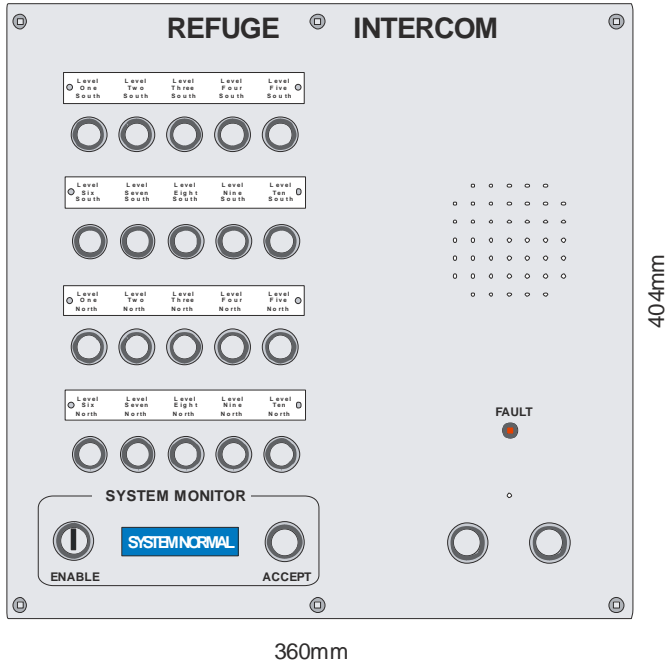
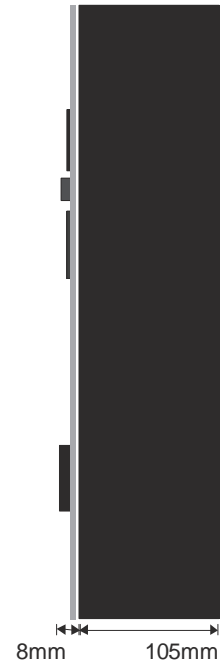

Fig 11:30 Standard System Twenty Way Master Station Features

Panel



Console Mount



Flush Fitting Bezel

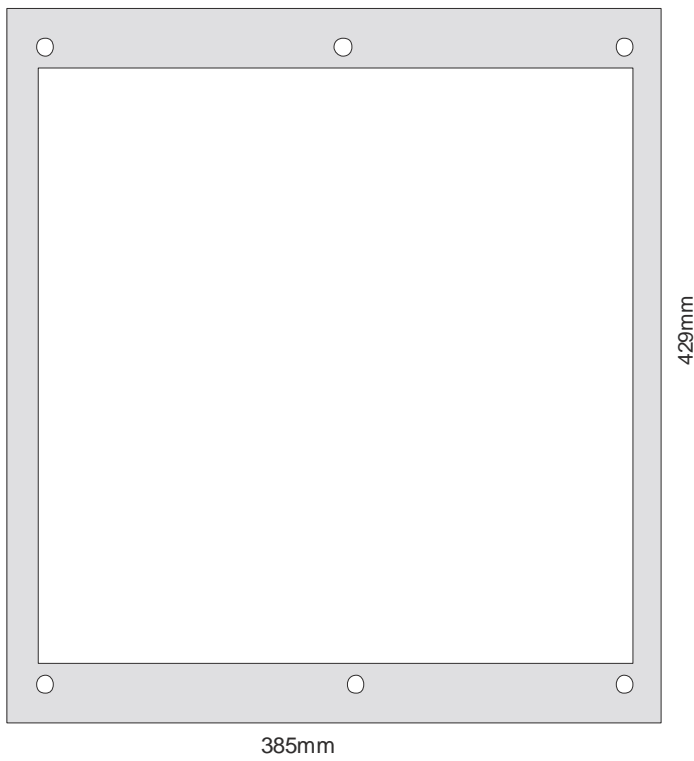

Flush Mount

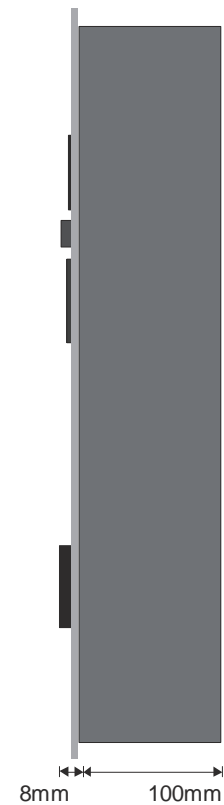

Fig 11:31 Standard System Twenty Way Master Station Dimensions

Fascia:	Stainless steel, finished, black annotation
Console mount:	Wood surround, black painted, mild steel flush back box insert.
Flush back box:	Mild steel
Dimensions (console mount):	Width 360mm, Height 404mm, Depth 113mm (approx.)
Dimensions (flush mount):	Width 360mm, Height 404mm, Depth 108mm (approx.)
Power:	24V from standard system monitored battery backed PSU
Audio output:	Max: 80 dB

11.10.5 Connections

Standard Master Station

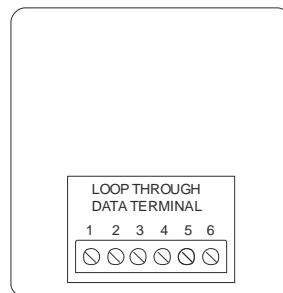

Fig 11:32 Standard Master Station Connections

11.11 STANDARD SYSTEM CONTROLLER (P/N RA7700.02)

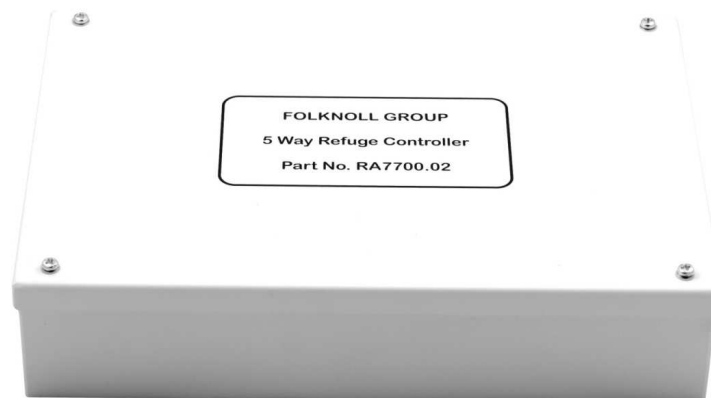

Fig 11:33 Standard System Controller

11.11.1 Features

- Controls up to 5-off slave outstations
- Microphone level adjust for slave outstations
- Speaker volume adjust for slave outstations
- I/O for BMS or other external systems
- Fused
- Mild steel surface mount enclosure
- Knockouts for cable glands designed to accommodate larger fire resistant cables

11.11.2 Description

The standard system controller interfaces controls up to 5-off outstations. Outstations are star wired to the controllers using 2 pair cable. Controllers are looped together with the master station over 3 pair cable. The combination of loop and star cabling enables installers to match system cabling to building layouts.

The standard system controller allows adjustment of slave outstation microphone and speaker level.

The standard system controller will test the audio path to all slave outstations. Testing is triggered externally e.g. by BMS or timer. Faults are reported at the master station and there is a fault output for indication to external devices e.g. BMS.

The standard system controller is powered from the 3 pair loop through cable.

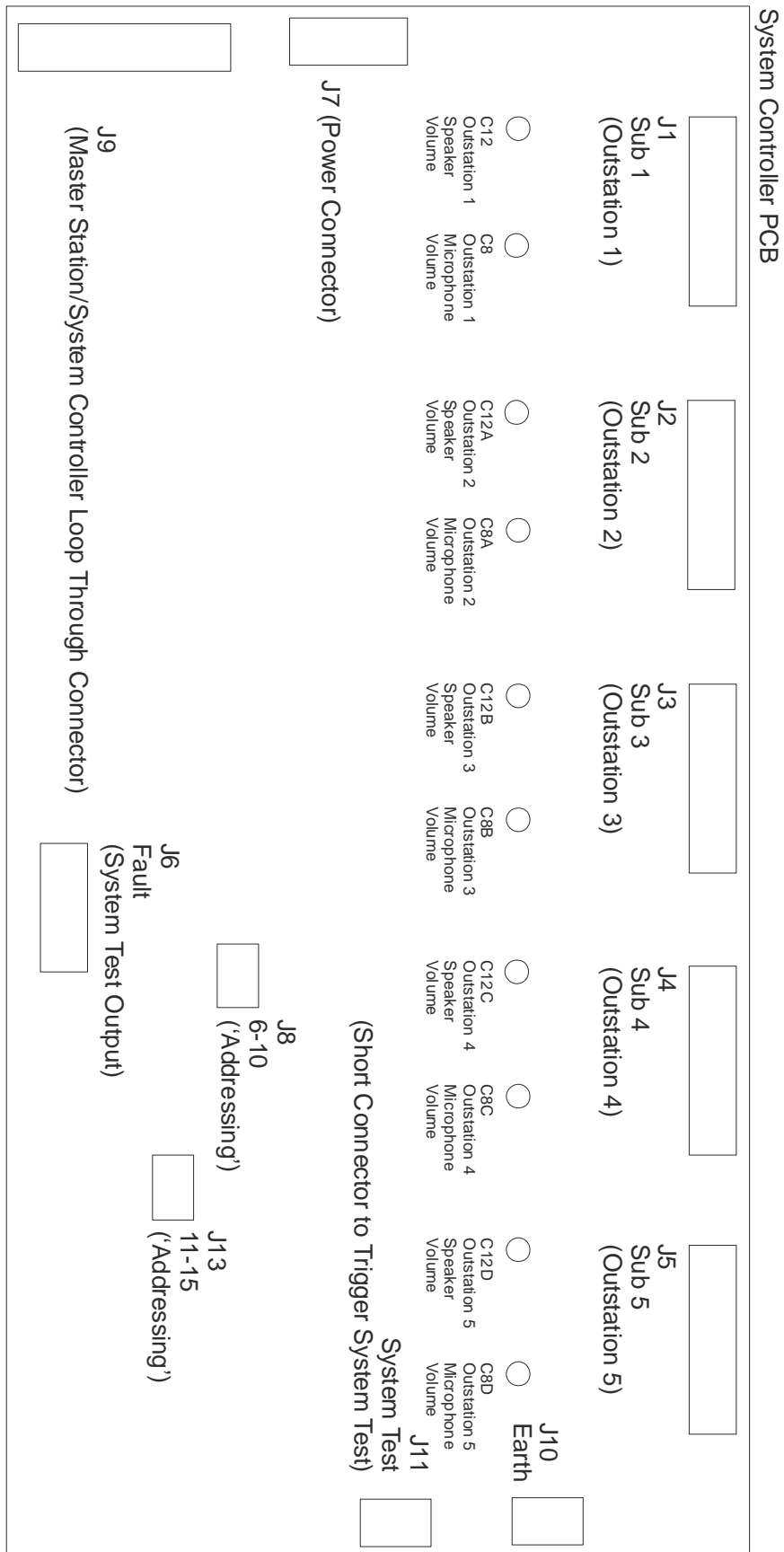

Fig 11:35 Standard System Controller PCB Layout

11.12 STANDARD SYSTEM BATTERY BACKED PSU (P/N RA7750.02, RA7750.04)



Fig 11:36 Standard System Power Supply Unit

11.12.1 Features

- Provides powers for standard Disabled Refuge EVC system with up to 20-off outstations
- Standby power
- Houses battery set for standby power
- Lockable, surface/wall mount, enclosure
- Mains fail monitoring (reported by master station)
- Local mains fail alarm, with silence button
- Status LEDs

11.12.2 Description

The standard system monitored PSU is the standard Disabled Refuge EVC system power supply and standby battery unit. The unit is usually mounted on a wall in an equipment room near to one of the standard system controllers.

The PSU unit is supplied fully enclosed and ready for wall mounting. The unit is convection cooled and should be mounted in a cool place with room for convection cooling to take place.

A single standard system monitored PSU will provide power for a complete Folknoll standard Disabled Refuge EVC system of up to 20-off outstations.

When fitted with a standard system battery set the PSU will provide power for 24 hours standby and 30 minutes operation in the event of a main supply failure.

The unit enables the mains supply to be monitored by the Disabled Refuge EVC system. Mains failure is reported by the master station.

The PSU unit has local mains fail alarm which can be silenced by means of a **SILENCE** button located on the outside of the enclosure.

11.12.3 Indicators

- External Green LED – Supply healthy
- External Yellow LED – Common fault (flashes if alarm sounder is silenced)
- Internal Yellow LED - Battery fault
- Internal Yellow LED - Mains fault
- Internal Yellow LED – Volts fault

11.12.4 Part Numbers

RA7750.02	Surface mount, standard system PSU
RA7750.04	Standard system PSU battery set

11.12.5 Specifications

Enclosure:	Mild steel (18 SWG)
Finish:	Metallic Silver (Radon MW334E) painted
Mounting:	Surface (5 holes in rear), 20m knockouts in top.
Dimensions (surface mount):	Width 400mm, Height 300mm, Depth 80mm (approx.)
ROHS:	Compliant lead free construction
Power:	90V-264V ac, <2amps, 47-63Hz.
Output:	19V d.c. min (battery) 30V d.c. max (mains)
Fuse (Input):	T3.1A 250 V a.c.
Fuse (Load):	5A self setting Polyfuse
Fuse (Battery Bypass):	6.3A (not replaceable)

11.12.6 Connections

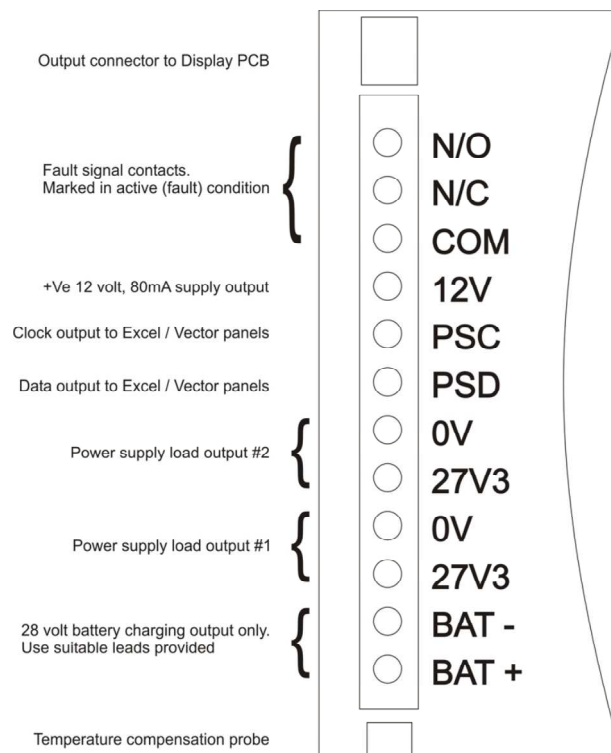

Fig 11:37 Standard PSU Connections

11.12.7 Monitored PSU Schematic

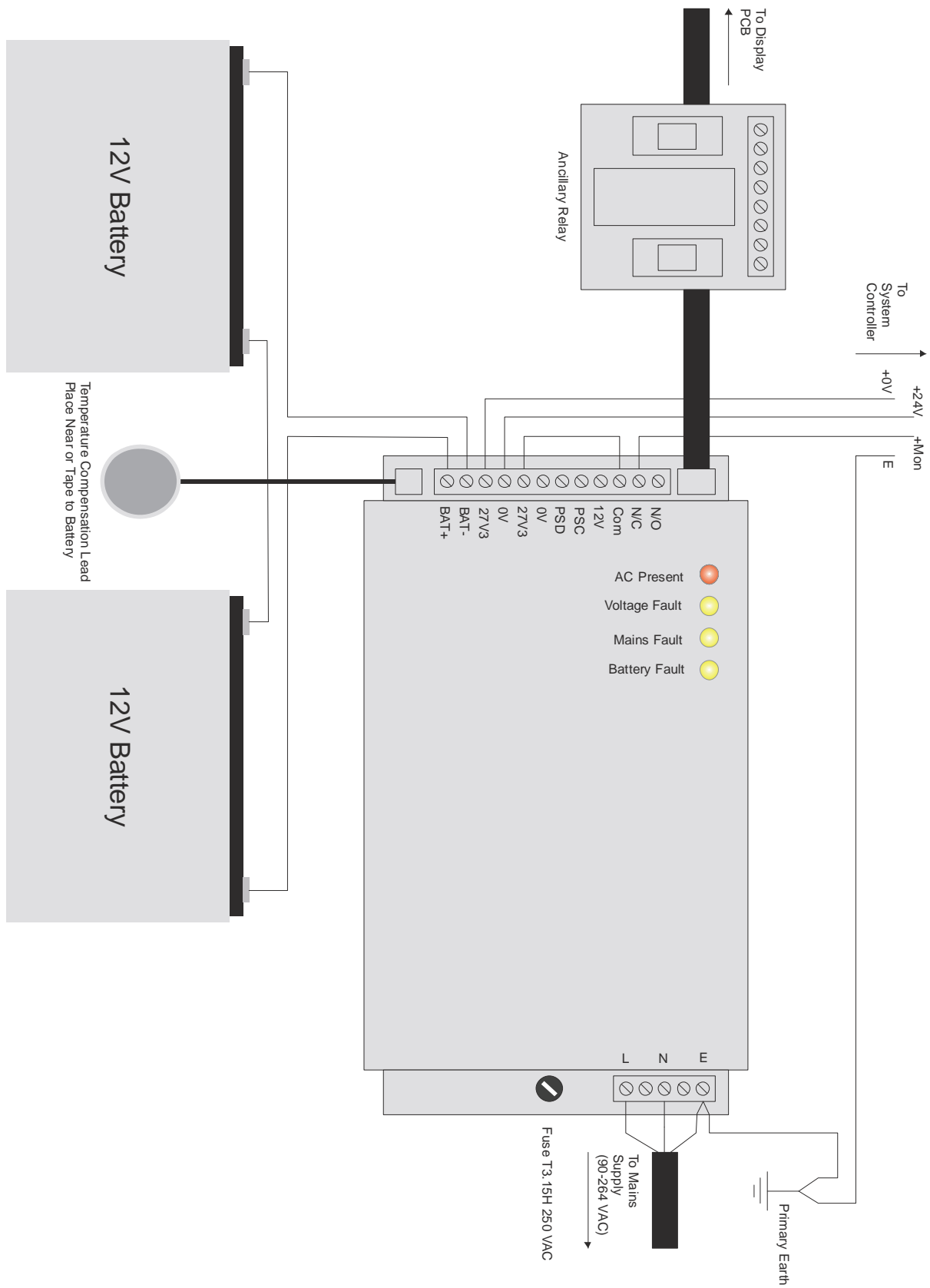

Fig 11:38 PSU General Layout

12 APPENDIX A FIRETUF CABLES



CIRCUIT INTEGRITY ALARM CABLE

Zero Halogen, Low Smoke (OHLS®) cable, maintaining circuit integrity when exposed to fire. Meeting the Enhanced category of BS 5839-1:2002. Manufactured to BS 7629-1. Tested and approved by LPCB and BASEC.

FT120 has been specially designed to meet the Enhanced requirements detailed in BS 5839-1:2002, Clause 26.2e. It therefore meets the PH120 class, and additionally meets the requirements for integrated water spray and mechanical shock also described in Clause 26.2e, and detailed in BS 8434 Part 2:2003:

60 mins - fire and mechanical impact, followed by
60 mins - fire, mechanical impact and water

FT120 achieves the Enhanced performance, whilst retaining all the advantages associated with a pliable cable. These include:

- Lower termination costs
- No special tools or training
- Ease of handling and installation
- Available in long lengths
- Twisted core construction to improve signal clarity
- Suitable for use in Zone 1 and Zone 2 hazardous areas

FT120 achieves the Enhanced performance by application of state of the art materials technology, providing advanced resistance to fire and heat, enabling the maintenance of circuit integrity through this most onerous testing protocol.

Construction

Conductors: Solid or stranded plain annealed copper wire.
Insulation: Enhanced silicone rubber.
Binder: Enhanced close weave glass tape.
Conductor (earth): Solid or stranded tinned annealed copper.
Electrostatic screen: Enhanced aluminium/polyester laminated tape.
Sheath: Enhanced Thermoplastic Zero Halogen, Low Smoke (OHLS®) compound.

Physical Characteristics

Voltage rating (U_o/U): 300/500V.
Operating temp: -40°C to +90°C (The cable should not be flexed when either the ambient or cable temperature is below 0°C).
Min. bending radius: 6 x overall diameter of cable.

Standards Achieved

Circuit integrity: BS 5839-1:2002 Clause 26.2e Enhanced.
BS 8434-2:2003.
BS EN 50200 PH120.
BS 6387 C, W & Z.
Flame propagation: BS EN 60332-1, BS EN 60332-3.
Acid gas emission: IEC 60754, BS EN 50267.
Smoke emission: BS EN 61034

LPCB
TESTED &
CERTIFIED
BASEC



Cable ref.	No. of cores	Conductor Class	CSA mm ²	Protective earth conductor CSA mm ²	Nominal overall diameter mm	Approx. nett weight kg/km
FTPLUS2EH1.5	2	1	1.5	1.5	8.6	130
FTPLUS3EH1.5	3	1	1.5	1.5	9.0	135
FTPLUS4EH1.5	4	1	1.5	1.5	10.1	170
FTPLUS2EH2.5	2	1	2.5	2.5	9.9	175
FTPLUS3EH2.5	3	1	2.5	2.5	10.6	200
FTPLUS4EH2.5	4	1	2.5	2.5	11.9	250
FTPLUS2EH4.0	2	2	4	4	11.7	250
FTPLUS3EH4.0	3	2	4	4	12.8	300
FTPLUS4EH4.0	4	2	4	4	14.4	370



Wellington Road, London Colney, Herts, AL2 1EY
Tel: 01727 828 828 - Fax: 01727 824 825
e-mail sales@fscables.com web: www.fscables.com



FIRETUFdata

2 Pair 0.65mm (0.33mm² – 22AWG)



FS Cables part number 387FTD203

Draka Comteq part number 910244

Application		Applicable Standards	
Fire resistant low smoke halogen free data cable providing circuit integrity and high speed data transmission. Ideal for use on B.M.S., alarm and evacuation systems in public buildings and tunnels.		Generally to ISO/IEC 11801:95, EN 50173 95 and EN 50288-2-1. Suitable for standard Insulation Displacement Connector L.A.N. sockets. RS-485 10Mb/s	
Cable Construction		Physical Characteristics	
Conductor	Bare Cu Wire	Outside Diameter of Conductor	0.65 mm
Insulator Material	PE/Sil Rbr	Outside Diameter of Insulation	1.70 mm
Number of Twisted Pairs	2 (two)	Outside Diameter of Sheath	8.10 mm
Glass Tape	Fibre	Weight	97 kg/km
Screen Material	Al/Mylar	Sheath Colour	Red
Braid	TCWB		
Sheath Material	OHLS		
Cable Properties		Electrical Characteristics @ 20°C	
Min. Installation Bend Radius	6 x Dia	Structural Return Loss SRI	IEC dB
Min. Installed Bending Radius	8 x Dia	Characteristic impedance @ 10MHz	100±5Ω
Max. Installation Tension	30N	DC Conductor Loop Resistance	<19 Ω/100m
Max. Installed Tension	Zero	Nominal Velocity of Propagation	57%
Installation Temp. Range	0°C to +50°C	Insulation Resistance (500V)	≥5000 MΩ.km
Installed Operating Temp. Range	-20°C to +60°C	Voltage	300/500V
Fire Tests & Standards		London Underground Tests & Approvals	
Fire Resistant BS5839 Enhanced	>2hrs @ 950°C	Fire Resistant BS5839-1 <small>Clause 26.2E</small>	>2hrs @ 950°C
Fire Resistant BS6387	>3hrs @ 950°C	Fire Resistant BS8434-2 2003	PH120 120min
Fire Resistant IEC60331-23	>3hrs @ 750°C	Fire Resistant BS EN 50200 2000	>3hrs @ 950°C
Fire Resistant BS EN 50200	>3hrs @ 950°C	Flame Retardant	BS4066 part 3
Flame Retardant	IEC60332-3-24	Smoke Emission	BS EN 20568
Corrosivity : acid & halogen free	IEC60754-1+2	LUL - Flammability, smoke & fume	2-01001-002
Smoke Test: low smoke emission	IEC61034-1+2	DP99 Compound approval	E4156 part 1
		LUL standard E4156 part 1	Approved

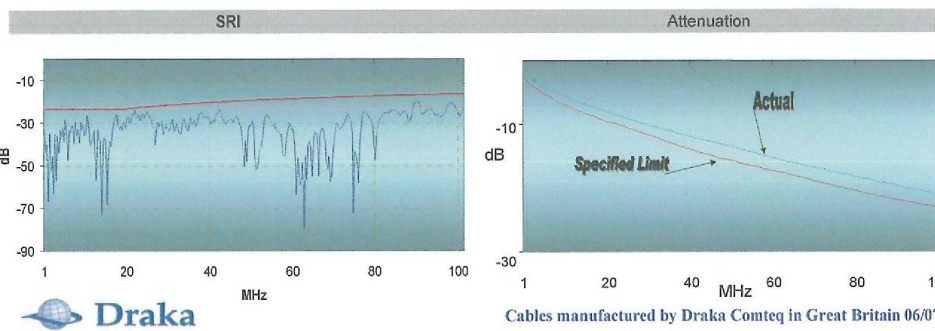

13 APPENDIX B COMPACT SYSTEM MASTER STATION LABELS

13.1 COMPACT SYSTEM MASTER STATION 5 WAY REFUGE AREA LABEL



Fig 13:1 Compact System Master Station 5 Way Refuge Area Label

13.2 COMPACT SYSTEM MASTER STATION 10 WAY REFUGE AREA LABEL

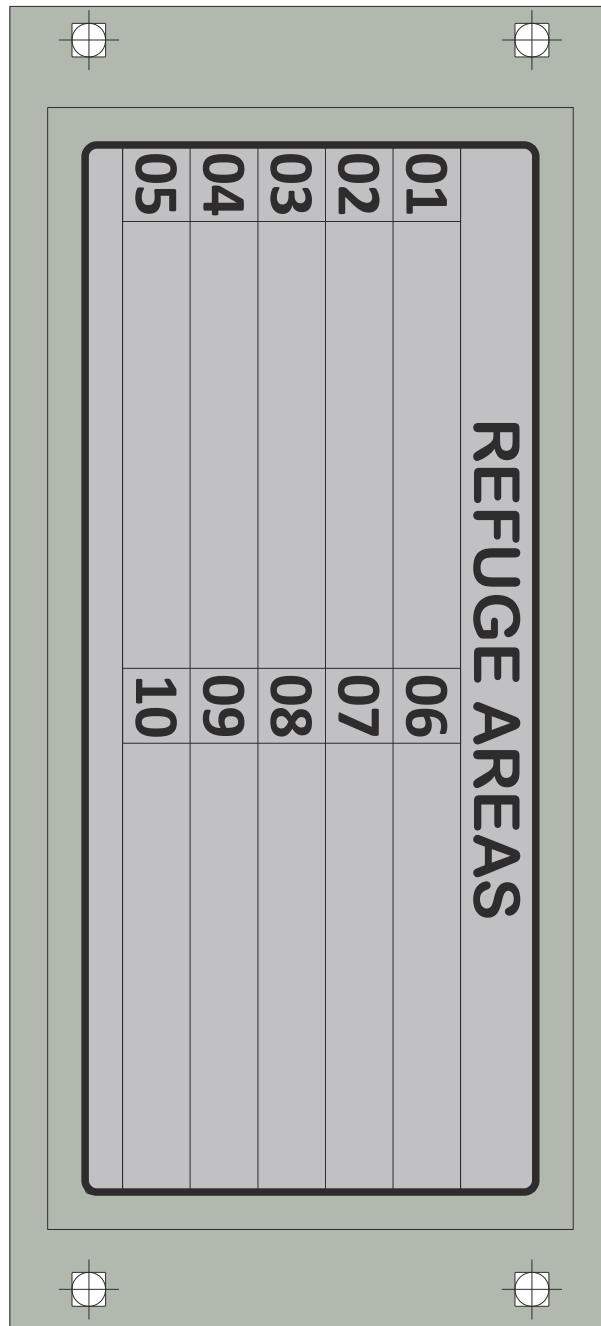
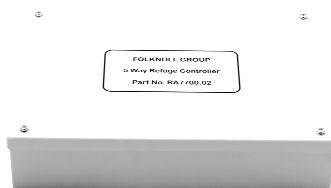

Fig 13:2 Compact System Master Station 10 Way Refuge Area Label

14 USER NOTES

This Section left blank for user notes.



Folknoll

Old North Rd, Royston, HERTS, SG8 5DT
 Tel: 01763234567
 sales@folknoll.co.uk
 www.folknoll.co.uk

CONTRACTORS HEALTH & SAFETY ASSESSMENT SCHEME
Accredited Contractor
www.chas.gov.uk